



विद्यारत्नम् महच्छनम्

राजीव गाँधी पेट्रोलियम प्रौद्योगिकी संस्थान जायस, अमेठी,
उ. प्र.

RAJIV GANDHI INSTITUTE OF PETROLEUM TECHNOLOGY

Jais, Amethi (U.P.) – 229 304

Website: www.rgipt.ac.in

E-TENDER FOR CIVILWORKS FOR ESTABLISHMENT OF CRF LAB

PART – A : TECHNICAL BID

NOTICE INVITING TENDER NO. : RGIPT/JAIS/IWD/CRF TENDER CIVIL/01/2020-21

DATED: 24.06.2020

Last Date & Time of Submission: 14/07/2020 (Tuesday) by 3:00 P.M

RAJIV GANDHI INSTITUTE OF PETROLEUM TECHNOLOGY

Jais, Amethi (U.P.) – 229 304

Tender Documents for Civil Works for establishment of CRF lab at RGIPT, Jais Campus

TABLE OF CONTENTS		
Sl. No.	Description	Page No.
	Technical Bid (Part A)	
01.	Schedule of Events	3 – 3
02.	Instructions For Online Bid Submission	4 – 7
03.	Notice Inviting E-Tender	8 – 11
04.	General Terms & Conditions	12 – 19
05.	Scope of Work	20 – 20
06.	List of Approved Makes	20 – 20
07.	Drawings	21 – 23
08.	Annexure -1 (Technical Bid Format)	24 – 24
09.	Annexure - 2 (Average Annual Financial Turnover)	25 – 25
10.	Annexure -3 (Details Of Work Of Similar Nature)	26 – 26
11.	Annexure -4 (No Claim Certificate)	27 – 27
12.	Annexure -5 (No Conviction Certificate)	28 – 28
13.	Check List	29 – 29
	Price Bid (Part B)	
14.	Price Bid	30 – 35

Schedule of Events

Rajiv Gandhi Institute of Petroleum Technology (RGIPT) invites item rate (unit rate) e-tender under Two Part Bid System (Technical Bid and Financial Bid) from reputed, experienced and financially sound parties for Civil Works for establishment of CRF Lab at RGIPT Jais Campus.

Name of the Work	Civil works for establishment of CRF Lab at RGIPT, Library & Computer Center area.
Estimated Value	Rs. 10,17,193/- (Rupees Ten Lakh Seventeen Thousand One Hundred Ninety Three) only.
Notice Inviting Tender No.	Tender No: RGIPT/JAIS/IWD/CRF TENDER CIVIL/01/2020-21, Date- 24/06/2020
EMD	Rs. 30,516/- (Rupees Thirty Thousand Five Hundred Sixteen) through e-payment Gateway available on https://rgipt.euniwizarde.com
e-Tender Processing Fee (ITI LIMITED)	Rs.1200/- through e-payment Gateway available on https://rgipt.euniwizarde.com
Work Completion Period	The work completion period of contract shall be of 45 Days from date of issue of work order.
Issue of Tender	The Tender document link can be obtained from the Institute website – www.rgipt.ac.in and https://rgipt.euniwizarde.com (e-tendering website). Please keep visiting our website for any corrigendum /amendments and submit the bid documents.
Last Date & Time of Submission of Tender (Bid due date)	Up to 3:00 P.M. on 14/07/2020 (Tuesday)
Contact Person (for any clarification)	Executive Engineer (Civil), e-mail: hkyadav@rgipt.ac.in , Mobile No.+91-9565993399
Pre-Bid Meeting	3:00 P.M. on 06/07/2020 (Monday)
Opening of E-Tender	Part – A – Technical Bid Technical Bid will be opened online on same day, i.e. 14 th July' 2020 at 04:00 P.M. in the presence of authorized representatives of the bidders.
	Part – B – Financial Bid Financial Bid will be open for technically qualified bidders and shall be intimated for later date for online Financial Bid opening. The tender job will be awarded on overall L1 basis, not on individual item basis.
ITI Helpdesk Contact Detail	Helpdesk landline No.- “011-49606060“ Mobile Number- Mr. Birendra Kumar - 9205898228, Mr. Saurabh- 07042643428

E Tendering Helpdesk Number: 011-49606060/9205898228/7982696347/7042643428

E Tendering Helpdesk email ID: ewizardhelpdesk@gmail.com

ewizardhelpdesk89@gmail.com

Instructions for Online Bid Submission:

The bidders are required to submit soft copies of their bids electronically on the e-tender Portal, using valid class 3 Digital Signature Certificates. The instructions given below are meant to assist the bidders in registering on the e-tender Portal, prepare their bids in accordance with the requirements and submitting their bids online on the e-tender Portal.

More information useful for submitting online bids on the e-tender Portal may be obtained at: <https://rgipt.euniwizarde.com>.

REGISTRATION

1. Bidders are required to enroll on the e-Procurement Portal (URL: <https://rgipt.euniwizarde.com>) with clicking on the link “Online bidder Registration” on the e-tender Portal by paying the **Registration fee of Rs. 2360/- Per vendor/per year**.
2. As part of the enrolment process, the bidders will be required to choose a unique username and assign a password for their accounts.
3. Bidders are advised to register their valid email address and mobile numbers as part of the registration process. These would be used for any communication with the bidder.
4. Upon enrolment, the bidders will be required to register their valid Digital Signature Certificate (**Only Class III Certificates with signing + encryption key usage**) issued by any Certifying Authority recognized by CCA India (e.g. Sify / TCS / nCode / eMudhra etc.), with their profile.
5. Only one valid DSC should be registered by a bidder. Please note that the bidders are responsible to ensure that they do not lend their DSC’s to others which may lead to misuse.
6. Bidder then logs in to the site through the secured log-in by entering their user ID /password and the password of the DSC / e-Token.

7. The scanned copies of all original documents should be uploaded on portal <https://rgipt.euniwizarde.com>

SEARCHING FOR TENDER DOCUMENTS

1. There are various search options built in the e-tender Portal, to facilitate bidders to search active tenders by several parameters.
2. Once the bidders have selected the tenders they are interested in, you can pay the form fee and processing fee (NOT REFUNDABLE) by net-banking / Debit / Credit card then you may download the required documents / tender schedules, Bid documents etc. Once you pay both fee tenders will be moved to the respective 'requested' Tab. This would enable the e-tender Portal to intimate the bidders through SMS / e-mail in case there is any corrigendum issued to the tender document.

PREPARATION OF BIDS

1. Bidder should take into account any corrigendum published on the tender document before submitting their bids.
2. Please go through the tender advertisement and the tender document carefully to understand the documents required to be submitted as part of the bid.
3. Bidder, in advance, should get ready the bid documents to be submitted as indicated in the tender document / schedule and generally, they can be in PDF formats. Bid Original documents may be scanned with 100 dpi with Colored option which helps in reducing size of the scanned document.
4. To avoid the time and effort required in uploading the same set of standard documents which are required to be submitted as a part of every bid, a provision of uploading such standard documents (**e.g. PAN card copy, annual reports, auditor certificates etc.**) has been provided to the bidders. Bidders can use "My Documents" available to them to upload such documents.
5. These documents may be directly submitted from the "My Documents" area

while submitting a bid, and need not be uploaded again and again. This will lead to a reduction in the time required for bid submission process.

SUBMISSION OF BIDS

1. Bidder should log into the website well in advance for the submission of the bid so that it gets uploaded well in time i.e. on or before the bid submission time. Bidder will be responsible for any delay due to other issues.
2. The bidder has to digitally sign and upload the required bid documents one by one as indicated in the tender document as a token of acceptance of the terms and conditions laid down by RGIPT, Jais.
3. Bidder has to select the payment option as **“e-payment” to pay the tender fee / EMD** as applicable and enter details of the instrument.
4. Bidders are requested to note that they should necessarily submit their price bid (financial bids) in the format provided and no other format is acceptable. If the price bid has been given as a standard BOQ format with the tender document, then the same is to be downloaded and to be filled by all the bidders. Bidders are required to download the BOQ file, open it and complete the white Colored (unprotected) cells with their respective financial quotes and other details (such as name of the bidder). No other cells should be changed. Once the details have been completed, the bidder should save it and submit it online, without changing the filename. If the BOQ file is found to be modified by the bidder, the bid will be rejected.
5. The server time (which is displayed on the bidders’ dashboard) will be considered as the standard time for referencing the deadlines for submission of the bids by the bidders, opening of bids etc. The bidders should follow this time during bid submission.
6. All the documents being submitted by the bidders would be encrypted using PKI encryption techniques to ensure the secrecy of the data. The data entered cannot

be viewed by unauthorized persons until the time of bid opening. Data storage encryption of sensitive fields is done. Any bid document that is uploaded to the server is subjected to symmetric encryption using a system generated symmetric key. Further this key is subjected to asymmetric encryption using buyers/bid openers public keys. Overall, the uploaded tender documents become readable only after the tender opening by the authorized bid openers.

7. The uploaded tender documents become readable only after the tender opening by the authorized bid openers.
8. Upon the successful and timely submission of bid click “Complete” (i.e. after Clicking “Submit” in the portal), the portal will give a successful Tender submission acknowledgement & a bid summary will be displayed with the unique id and date & time of submission of the bid with all other relevant details.
9. The tender summary has to be printed and kept as an acknowledgement of the submission of the tender. This acknowledgement may be used as an entry pass for any bid opening meetings.

ASSISTANCE TO BIDDERS

Any queries relating to the tender document and the terms and conditions contained therein should be addressed to the Tender Inviting Authority for a tender or the relevant contact person indicated in the tender.

Any queries relating to the process of online bid submission or queries relating to e-tender Portal in general may be directed to the 24x7 Helpdesk Support. **The contact number for the helpdesk is “011-49606060”**

NOTICE INVITING E-TENDER

1. Online E- Tenders on Item Rate (Unit Rate) basis are hereby invited under ‘Two Part Bid System’ i.e. Technical Bid and Financial Bid for Civil Work tender, under the heading “Civil Work for Establishment of CRF Lab at RGIPT Computer Center & Library Area” from reputed, experienced and financially sound Contractors of government departments/ Autonomous Bodies / National Level Institution / PSUs.

Eligibility Criteria

The tenderers should have successfully completed similar works (Construction / Repair & Renovation of Building / Other Civil structures) during last seven (7) years ending on 31st May, 2020 should be either of the following: -

- a) Three similar completed works each of costing not less than the amount equal to 40 (forty) percent (Rs. 4,06,877/-) of the estimated cost; or
- b) Two similar completed works each of costing not less than the amount equal to 50 (fifty) percent (Rs. 5,08,597/-) of the estimated cost; or
- c) One similar completed work each of costing not less than the amount equal to 80 (eighty) percent (Rs. 8,13,754/-) of the estimated cost.

The value of executed works shall be brought to current costing level by enhancing the actual value of work at simple rate of 7% per annum; calculated from the date of completion to the date of opening of technical bid. This calculation shall be based on the completed day's basis.

This calculation shall be based on the completed days basis, (example If a work is completed on 30.12.2018, and the date of opening of technical bid is 31/03/2020, then the enhancement shall be for 1 years and 90 days (1 year of 2019 + 1 day of Dec 2018 + 31 days of Jan 2020 + 29 days of Feb 2020 + 30 days of March 2020) and the applicable percentage enhancement shall be $(7\% + 7\% \times 91/366)$.

The tenderers are required to produce proof of fulfilling these conditions (along with **Annexure-3** duly filled in) while submitting tender. The Technical Bid should contain all the relevant information and desired enclosures in the prescribed format along with Earnest Money Deposit (EMD). The Price Bid should contain only commercial. In case, any bidder encloses the price (financial) bid within technical bid, the same shall be rejected summarily.

2. The estimated cost of the project is of Rs. 10,17,193/- only (Rupees Ten Lacs Seventeen Thousand One Hundred Ninety Three only) which is inclusive of all taxes. The basis for deriving this estimated cost is based upon CPWD DSR and Market Rates.
3. The total time for carrying out the work will be 45 days. The date of commencement shall be reckoned from the 7th day of issue of award letter/work order.
4. Tenders should be on the specified form (non-transferable) which may be obtained from website <https://rgipt.euniwizarde.com>
5. The Earnest Money Deposit (EMD) amounting to Rs.30,516/- (Rupees Thirty Thousand Five Hundred & Sixteen Only) through e-payment Gateway available on <https://rgipt.euniwizarde.com> should accompany the tender. Tender received without EMD will be invalid and rejected.
6. The bid security (EMD) shall be returned to the unsuccessful bidders after finalization of tender without any interest.
7. Price bids of only those bidders will be opened, who qualify in the technical bids.

- 8.** The Institute does not bind himself to accept the lowest or any tender and reserves to himself the right of accepting the whole or any part of the tender and the tenderer shall be bound to perform the same at the rates as quoted.
- 9.** Canvassing in connection with the tenders is prohibited and the tenders submitted by the contractor who resort to canvassing are liable for rejection.
- 10.** Tender submitted shall remain valid for 120 days from the date of opening for the purpose of acceptance and award of work.
- 11.** No Engineer of Gazetted Rank or other Gazetted Officer employed in Engineering or Administrative duties in an Engineering Department of the Government of India is allowed to work as a contractor for a period of one year after his retirement from Government service, without the prior permission of the Government of India in writing. This contract is liable to be cancelled if either the contractor or any of his employees is found any time to be such a person who had not obtained the permission of the Government of India as aforesaid before submission of the tender or engagement in the contractor's service.
- 12.** The tenderer should see drawings and in case of doubt obtain required particulars, which may in any way influence his tender from the Engineer as no claim whatsoever will be entertained for any alleged ignorance thereof.
- 13.** Before tendering, the tenderer shall inspect the sites to fully acquaint himself about the condition in regard to accessibility of site, nature and extent of ground working condition of site and locally including stacking of materials, installation of tools and plants (T&P) etc. conditions affecting accommodations and movement of labour etc. required for the satisfactory execution of the work contract. No claim whatsoever on such account shall be entertained by the Institute in any circumstances.

14. If the contractor fails to commence the work as per Work Order then the Earnest Money will be forfeited.

15. SECURITY DEPOSIT:

15.1 The contractor shall be required to deposit an amount equal to 5% of the contract value as security deposit through Demand Draft in favour of “Rajiv Gandhi Institute of Petroleum Technology” payable at “Jais” within 7 days from the date of issuance of Work Order. If required, the EMD can be converted into security deposit after submission of written application and submission of balance amount by Demand Draft.

15.2 Security deposit shall be released to the contractor without interest after completion of all contractual obligations of the work based on ‘Completion Certificate’ issued by the competent authority and on submission of No Claim Certificate by the Contractor. The security deposit shall be valid for a period of 60 (Sixty) days beyond the period of Defect Liability Period (DLP).

15.3 In case of termination of contract, the security deposit shall be forfeited.

16. The pre-bid meeting will held at Office of the Dean of Students’ Affairs on 6th July, 2020 at 3:00 PM. The corrigendum of the said pre-bid meeting, if any, will be uploaded on CPP Portal as well as on RGIPT’s e-tender website. The bidders are therefore, requested to kindly check the portals before submission of their e-tender.

17. To acquaint themselves with the work, all the bidders are requested to visit the site by contacting the IWD Office on any working day (Monday to Friday) between 11:00 Hrs. to 16:00 Hrs. from 24th June, 2020 to 14th July, 2020 at RGIPT Jais Campus, Amethi or call on +91-9565993399.

18. RGIPT, Jais, Amethi reserve the right to accept or reject all or any bid/quotation without assigning any reason thereof.

GENERAL TERMS & CONDITIONS

1) INTERPRETATION

WORK OR WORKS:

Shall mean all work or works define in schedule of quantities, specifications and such other work or works as the contractor may be entrusted with for carrying out under this contract.

INSTITUTE:

Shall mean Rajiv Gandhi Institute of Petroleum Technology, Jais, Amethi.

ENGINEER:

Shall mean the Engineer designated by the Institute to superintend and perform other duties as indicated in the contract.

CONTRACTOR:

Shall mean the individual or firm or company, whether incorporated or not undertaking the work and shall include the legal personal representative or such individual or the persons composing such firms or company or the Successor of such firm or company and the permitted assignees of such individual or firm(s) or Company.

SITE:

Shall mean the site of contract works including any buildings and erection thereon and any other land adjoining thereto (inclusive) as aforesaid allotted by the Institute or the Engineer-in-Charge for the contractors use.

2) SUBMISSION OF TENDER:

Tenders should be submitted online in two Parts separately, i.e. “Technical bid” (Part-A) and “Price bid” (Part-B).

3) TECHNICAL BID (PART –A):

To qualify in the Technical Bid, the firm should have the minimum eligibility criteria; the firm in this regard should submit the following documents-

- a) Duly filled format of Technical Bid as per **Annexure “1”**.
- b) The bidder should be an Indian Registered Company under Companies Act 1956/ Proprietorship / Firm / Company of any of these. Copy of Certificate of Incorporation / Registration or any other relevant document, as applicable, should be submitted along with a copy of address proof Copy of constitution or legal status of the sole proprietorship / firm / company etc.
- c) Average Annual Financial Turnover during the last 3 years, ending 31st March 2019, should be at least 50% of the estimated cost of the work.
(Please submit Annual Report in **Annexure – 2**, as certified by Chartered Accountant (Balance Sheet and Profit & Loss Account) for the last 3 (three) financial year’s i.e. from 2016-17, 2017-18 & 2018-19).
- d) The technical bid should be accompanied by EMD for bid security of the amount.
- e) Copy of Income Tax Return Filed Acknowledgement for last 3 (three) financial year’s i.e. from 2016-17, 2017-18 & 2018-19) should be enclosed.
- f) Copy of PAN Card.
- g) Copy of GSTIN registration certificate.
- h) Copy of Bank Account details
- i) Proof of Registration of EPF, ESI
- j) The bidder must have adequate experience for execution of works in Central / State Government Department /Semi Government department/ PSU/ Autonomous bodies having completed one, two, or three similar works in last

seven years, as mentioned in Para 1 of page no. 8 of this tender. Necessary supporting documents in support of similar works like work orders must be submitted along with the offer.

k) Tenderer should upload the complete tender document duly signed and stamped.

4) PRICE BID (Part –B):

The financial bid shall be submitted online in the prescribed format only. In this bid, the bidder is required to quote his item rates in the BOQ attached in accordance with the scope of work, terms & conditions & technical specifications enclosed. The rates/price quoted by contractor should be all inclusive i.e. should include all material cost, labour, services, plant/machinery/tools & tackles, ladders & scaffolding required for work, freight, Insurance, Govt. duties & levies, taxes (GST), transport/cartage of materials/labour and all other expenses not specifically mentioned but reasonably implied. Nothing over and above these rates shall be payable to contractor. Further nothing extra in rates will be considered for any variations in tender quantities or due to any site difficulties. It is mandatory for bidder to quote all items rate as asked for in the BOQ/ PRICE schedule. Failure in not filling some item rates will lead to rejection of tender. The tender job will be awarded on overall L1 basis, not on individual item basis.

5) PRICE VARIATION:

No escalation over and above items rates quoted by the bidder shall be paid during the execution of contract.

6) COMPLETION TIME:

The total time for carrying out the work will be 45 days. The date of commencement shall be reckoned from the 7th day of issue of award letter/work order. Time is the essence of the contract.

7) EXTENSION OF TIME:

7.1 If the contractor desires for extension of time in respect of completion of work, on the grounds of his having been unavoidably hindered in its execution or any other ground, he shall apply in writing to the Dean, Students' Affairs, on account of which he desires extension, as aforesaid, and the Dean, Students' Affairs shall, in his opinion (which shall be final) reasonable grounds shown therefore, authorize such extension of time if any, which may in his opinion be necessary or proper.

7.2 In the event, the value of work exceeds the value of the bill of quantities owing to variations, the contractor shall be entitled to ask for extension of time in proportion to the increase value of the work.

8) PAYMENT TERMS & CONDITIONS:

8.1 RGIPT will not pay any mobilization advance for the work. Progressive payment will be paid during the progress of the work on the basis of the actual work done, measured and approved by RGIPT.

8.2 Full and Final payment will be paid on the basis of the actual work done, measured and approved by RGIPT upon satisfactory completion of the work.

9) DEFECT LIABILITY PERIOD:

Defect Liability Period shall be 2 (two) months from the date of completion of all contractual obligations of the work based on 'Completion Certificate' issued by the competent authority.

10) LIQUIDATED DAMAGES:

The contractor shall pay liquidated damages an amount equal to 0.5% of the contract value, for every week, that the work remains un-commenced or unfinished or due quantity of work remains incomplete after the schedule date of completion of the work. Liquidated damages to be paid shall not exceed 5% of the contract value.

- 11)** If any extra or substituted item appears in the work, contractor shall submit its rate analysis supported with documents, which shall be approved by RGIPT. If required, RGIPT can make its own analysis based on DSR document of CPWD or based on market rates for determining item rate.
- 12)** The quantities mentioned in the tender are approximate. The running payment shall be made on the basis of actual work executed. Variation in the quantities, if any, shall not vitiate the contract.
- 13)** The contractor shall normally have to make his own arrangement for storage of materials and staying of laboures. However, at the request of contractor, a room shall be allotted for storing of materials and staying of manpower, within the campus, depending upon the availability and subject to the approval of the concern committee. Under no circumstance, the labourer of the contractor will be allowed to cook the food within the RGIPT premises. However, at the request, the facility of food can be availed from the RGIPT mess area, on payment basis after getting the approval from the competent authority.
- 14)** Samples of all materials and other articles required for use on the work shall be got approved from Engineer-in-Charge, RGIPT before the starting of work.
- 15)** All material and article brought by the contractor to the site of work for use shall conform to the samples approved. Final decision to reject any material shall rest with the RGIPT.
- 16)** Some restrictions may be imposed by the security staff etc. on the working and for movement of labourer, materials etc. The contractor shall be bound to follow all such restrictions/instructions and nothing extra shall be payable on account of the same.
- 17)** The entire royalty at the prevalent rates shall have to be paid by the contractor on all the boulders, metals, sand etc. collected by him for execution of the work, directly

to the Revenue authority or authorized agents of the State Government concerned or the Central Government, as the case may be.

- 18) Makes of various materials to be used by contractor will be according to the list of approved makes given. RGIPT shall approve the sample from the brands mentioned in the approved list. No other makes will be used by the contractor. In case any item is not covered in said list of approved makes then it is the responsibility of the selected bidder to get the same approved from RGIPT whose decision shall be final and binding on the bidder.
- 19) Contractor will arrange proper ladders and staging (for working at higher levels) at his own cost and will take all safety measures like safety belts, extra labour to hold ladders/staging etc. If it is observed that work is proceeding without adequate safety precautions, work may be stopped by Engineer-In-Charge and in such cases, contractor will be solely responsible for delay and its consequences thereof.
- 20) Detailed technical specification for civil work with respect to materials & workmanship and mode of measurements will be as per IS codes and CPWD specifications, unless mentioned otherwise.
- 21) The rate of items of BOQ Sl. no. 7 is inclusive of providing and fixing granite for skirting work on wall and nothing extra on this account is admissible.

22) LABOUR LAWS:

The contractor will abide by all the rules and regulations related to labour laws, accident, workmen compensation act, workmen insurance etc. This will be the sole responsibility of the contractor. RGIPT will not be a party at any stage in any of the disputes relating to the above. In case, RGIPT has to bear any expenditure due to non-conformance of the above provisions by the contractor, the same will be recovered from contractor's bills.

- 23) EPF and ESI, if applicable, will be reimbursed on actual basis after due verification.
- 24) The contractor shall depute competent Engineer / Supervisor for day to day supervision, coordination, liaison and other works etc. The representative of the Contractor shall attend regular / required meetings to expedite the works and sort out difficulties, if any. The contractor is responsible for progress of works and also for hurdles, if any, in the progress of works, attributable to the contractor.
- 25) Contractor will take due permission for entry of all his workmen in RGIPT. No unauthorized person will be allowed to work inside.
- 26) The contractor will provide for all necessary materials, tools, equipment, access ladders & scaffolding, measuring instruments and working consumables etc. needed for execution of the works. Safe custody of all such material will be contractor's sole responsibility. No extra charges will be paid for the same. Watch and Ward of all material till the system is taken over by RGIPT shall be the sole responsibility of the contractor and pilferage etc. shall be entirely to his account.
- 27) During execution of work, the contractor should follow all standard norms of safety measures/precautions as per relevant IS codes and CPWD specifications to avoid accidents/damages to man, machines and buildings, at his own cost. Contractor will have his own arrangement to escort the labour to the nearest hospital for treatment in case any injury happens to any worker during execution of work.
- 28) No material belonging to the contractor whether consumable or non-consumable should be brought inside the RGIPT campus without proper entry at the Main Gate nor any material should be taken out without proper gate pass issued by the authorized representatives of the RGIPT.
- 29) During execution of the work, contractor should dispose off waste material on regular basis and should keep the area of work properly cordoned off and neat and

clean as far as possible. After completion of work, contractor should clear the site completely of all unwanted and junk material before submitting his final bill.

30) RGIPT will provide free water and electricity during execution of work at one point. The contractor has to make his own arrangements for supplying power and water from that point onwards as per his requirements.

31) FORCE MAJEURE:

Conditions beyond control of either parties like war, hostility, acts of public enemy, civil commotion, sabotage, serious loss or damage by fire, explosions, epidemics, strikes, lockouts or acts of God come under the legal concept of Force Majeure (FM). Delays in performance of contractual obligations under influence of FM conditions are condonable by the other party without any right to termination or damages, provided, notice of the happening of any such event is given by the affected party to the other within 30 (thirty) days from the date of occurrence. Works under the contract shall be resumed as soon as practicable after such event has come to an end or ceased to exist. However, if such event continues for a period exceeding 120 days, either party may at its option terminate the contract by giving notice to the other party.

32) ARBITRATION:

All disputes or differences whatsoever arising among the parties under and/or in connection with and/or in respect of this tender shall be referred to and decided by a sole arbitrator, who shall be appointed by the Director, RGIPT. The arbitration shall be conducted in accordance with Arbitration and Conciliation Act of 1996, along with its relevant amendments and the venue of the arbitration shall be in RGIPT, Jais, Amethi. The proceedings of arbitration shall be in English language.

SCOPE OF WORK

Scope of work shall include but is not limited to the following head:

- a) RCC
- b) Brickwork & Plaster
- c) Flooring (Skirting), Paint
- d) M.S. Grill, Collapsible Steel Shutter
- e) Aluminium Window, G I Color coated sunshade

LIST OF APPROVED MAKES

S.No.	Description of Items	Approved Makes
1	Cement	ACC, AMBUJA, MP BIRLA, JAYPEE, BINANI CEMENT, ULTRATECH
2	Steel Rebar / Structural Steel	TATA, SAIL, RASHITRIYA ISPAT, KAMDHENU
3	Plastic Emulsion Paint	BERGER, ASIAN PAINTS , DULUX, NEROLAC
4	Deluxe Multi Surface Paint	BERGER, ASIAN PAINTS, DULUX, NEROLAC
5	Aluminium Extrusions	HINDALCO, JINDAL
6	Clear Float Glass	SAINT-GOBAIN, MODIGUARD, TATA
7	Galvanized color coated sheet	TATA, BHUSHAN, JINDAL

DRAWINGS

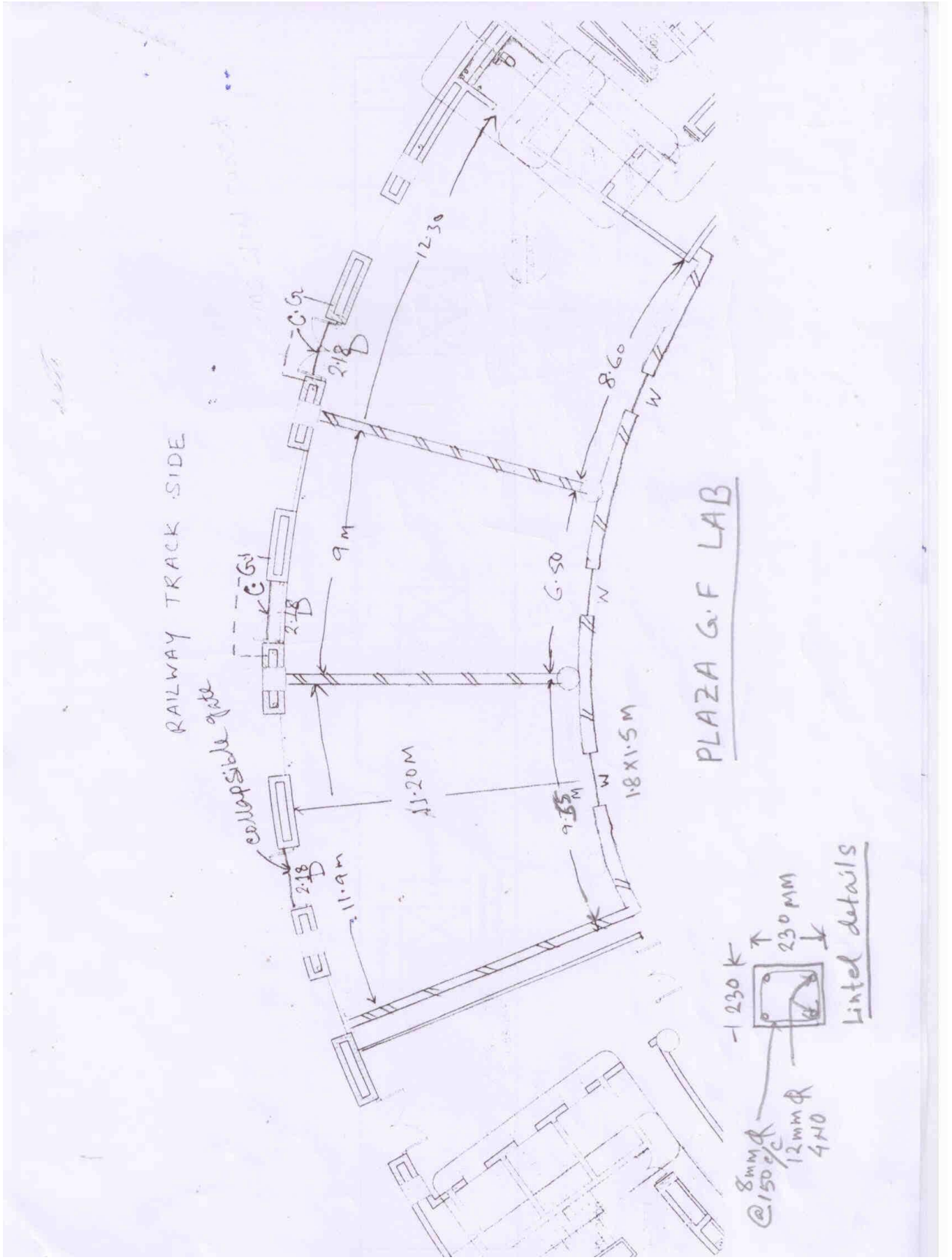

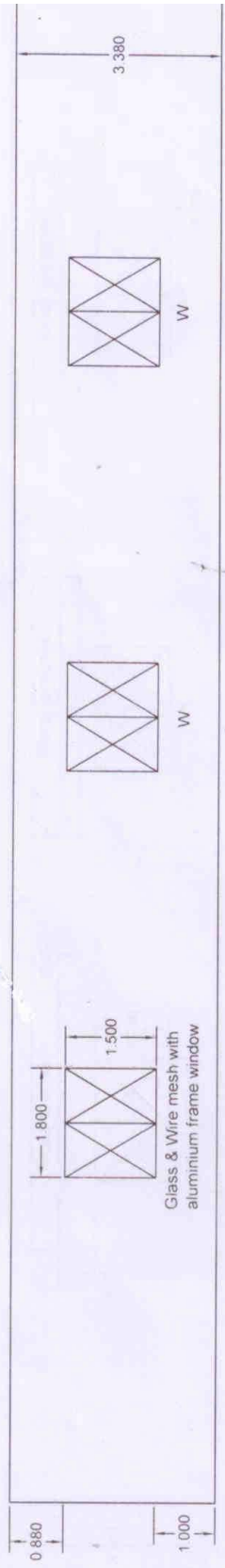

Elevation

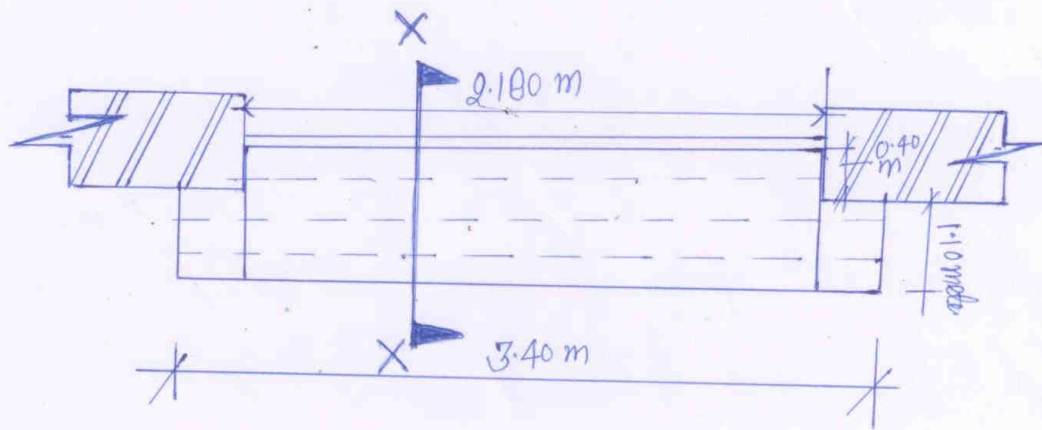
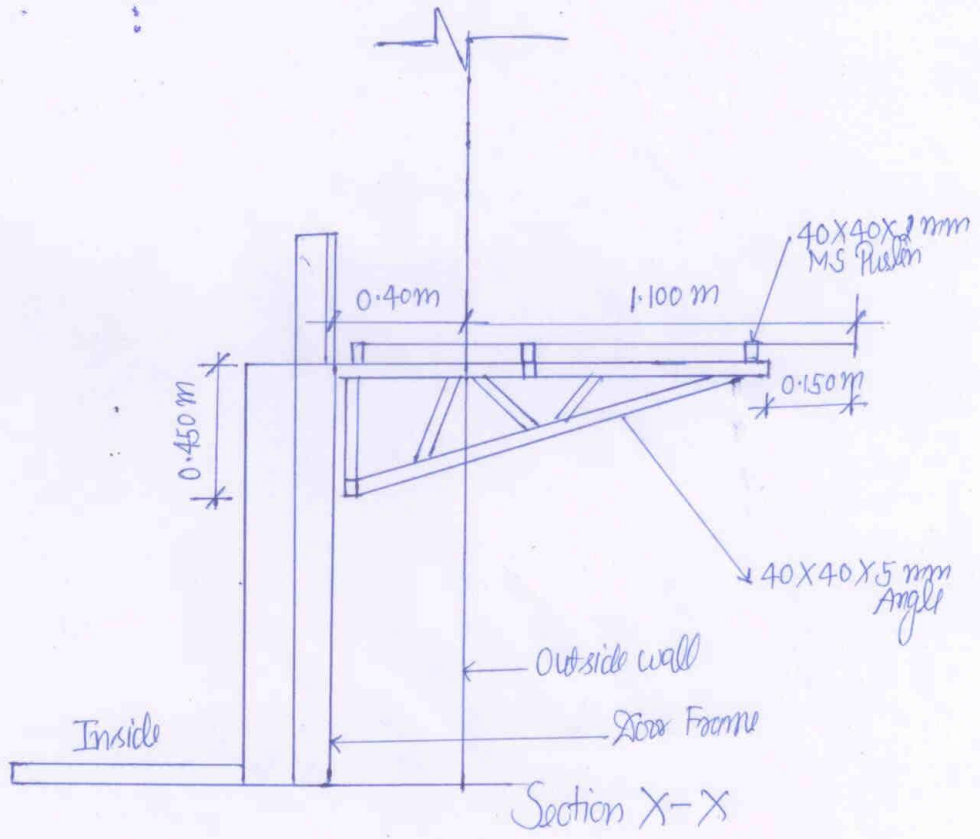

G.I. Corrugated Sheet Sunshade

TECHNICAL BID FORMAT

1	Name of the firm/ Society/ Company/ Proprietary Concern (Attach self-attested copy)	
2	Address of registered office	
3	Telephone Nos./ Mobile Nos. /E-mail	
4	Earnest Deposits money (EMD) Yes/No	
5	PAN (Attach self-attested copy)	
6	Bank Account details	
7	Proof of Registration of EPF, ESI (Attach self-attested copy)	
8	GSTIN Registration No. (Attach self-attested copy)	
9	Details of clients along with address, telephone and Fax numbers, Amount of contract, Duration of contract. (Attach a separate sheet in support of eligibility criteria).	

(Signatures of the authorized signatory
with seal of tendering firm)

AVERAGE ANNUAL FINANCIAL TURNOVER

Turnover of the Bidder in last 3 years (Please submit CA certified copy of Annual Reports)

Year	Annual Report Submitted (Yes / No)	Turnover in Rs. (Lakh)	Profit/ Loss
2016-2017			
2017-2018			
2018-2019			
Total			
Average			

DETAILS OF WORK OF SIMILAR NATURE

Details of similar work / order executed during last 7 years ending 31.05.2020 (Please submit copy of completion certificate from the client.

S. No.	Name of Work	Authority under whom the work has been executed	Agreement / acceptance letter reference with date of issue	Value of work as per agreement/ acceptance	Date of actual completion of work / extended date of completion	Value of the work completed	Supporting Document

NO CLAIM CERTIFICATE

(On company letterhead)

To,

(Contract Executing Officer)

Procuring Entity

Sub: Contract Agreement no. dated for the work of.....

We have received the sum of Rs..... (Rupees only) in full and final settlement of all the payments due to us for the work of under the above-mentioned contract agreement, between us and Rajiv Gandhi Institute of Petroleum Technology. We hereby unconditionally, and without any reservation whatsoever, certify that with this payment, we shall have no claim whatsoever, of any description, on any account, against Procuring Entity, against aforesaid contract agreement executed by us. We further declare unequivocally, that with this payment, we have received all the amounts payable to us, and have no dispute of any description whatsoever, regarding the amounts worked out as payable to us and received by us, and that we shall continue to be bound by the terms and conditions of the contract agreement, as regards performance of the contract.

Yours faithfully,

Signatures

Name of Contractor or Officer Authorised
to sign the contract documents on behalf of contractor
(Company stamp)

Date:

Place:

NO CONVICTION CERTIFICATE

(On company letterhead)

This is to certify that _____ (Name of the organization), having registered office at _____ (Address of the registered office) has never been blacklisted or restricted to apply for any such activities by any Central / State Government Department /Semi Government department/ PSU/ Autonomous bodies or Court of law anywhere in the country.

Yours faithfully,

Signatures

Name of Contractor or Officer Authorised
to sign the contract documents on behalf of
Contractor

(Company stamp)

Date:

Place:

Check List

Sl. No.	Particulars	Documents uploaded (Bidders to tick Yes/No)
1	Technical Bid (Part A)	
1.1	EMD of Rs. 30,516/- through e-payment Gateway available on https://rgipt.euniwizarde.com	Yes / No
1.2	Company / Firm covering letter	Yes / No
1.3	EPF, ESI Registration	Yes / No
1.4	PAN No, GSTIN No., Bank Account details	Yes / No
1.5	Copy of Income Tax Return Filed Acknowledgement	Yes / No
1.6	Copies of work order and completion certificates of works of similar nature	Yes / No
1.7	Copy of Annual Financial Turnover	Yes / No
1.8	Copy of No Conviction Certificate	Yes / No
2	Price Bid (Part B)	
2.1	BOQ	Yes / No

Note: - Scanned copy of entire NIT is to be attached duly signed & stamped by the bidder.



विद्यारत्नम् महच्छनम्

राजीव गाँधी पेट्रोलियम प्रौद्योगिकी संस्थान जायस, अमेठी,
उ. प्र.

RAJIV GANDHI INSTITUTE OF PETROLEUM TECHNOLOGY

Jais, Amethi (U.P.) – 229 304

Website: www.rgipt.ac.in

E-TENDER FOR CIVILWORKS FOR ESTABLISHMENT OF CRF LAB

PART – B : PRICE BID

NOTICE INVITING TENDER NO. : RGIPT/JAIS/IWD/CRF TENDER CIVIL/01/2020-21

DATED: 24.06.2020

Last Date & Time of Submission: 14/07/2020 (Tuesday) by 3:00 P.M

Name of work - Civil works for establishment of CRF lab at RGIPT Library & Computer Center area.

Bill of Quantities					
Sl. No.	Description	Unit	Quantity	Rate (Rs.)	Amount (Rs.)
1	Dismantling stone slab flooring laid in cement mortar including stacking of serviceable material outside the site area up-to all leads. (Note: - The Serviceable material recovered during dismantling work shall be property of Contractor. The agency may quote rates after considering the same. No extra payment shall be made for the carriage of the material.)	Sqm	17.28		
2	Brick work with common burnt clay F.P.S. (non-modular) bricks of class designation 7.5 in superstructure above plinth level up to floor V level in all shapes and sizes with Cement mortar 1:4 (1 cement : 4 coarse sand) all complete as per specification and direction of Engineer-In-Charge.	Cum	39.87		
3	Providing & applying plaster to wall with 12mm thick cement mortar 1:4 (1 cement: 4 coarse sand) with finished smooth, including scaffolding, curing, etc. for walls, beams, ribs, sills, jambs, ceiling etc. at all floor levels, all complete as per specifications and direction of Engineer in Charge.	Sqm	186.59		
4	Providing & applying plaster to wall on rough side with 15mm thick cement mortar 1:4 (1 cement: 4 coarse sand) with finished smooth, including scaffolding, curing, etc. for walls, beams, ribs, sills, jambs, ceiling etc. at all floor levels, all complete as per specifications and direction of Engineer in Charge.	Sqm	186.59		

Sl. No.	Description	Unit	Quantity	Rate (Rs.)	Amount (Rs.)
5	Reinforced cement concrete work in beams, lintels and lab counter above plinth level up to floor five level, including the cost of centering, shuttering, finishing with 1:1.5:3 (1 cement: 1.5 coarse sand : 3 graded stone aggregate 20 mm nominal size). all complete as per specifications and direction of Engineer in Charge.	Cum	3.05		
6	Supply and fixing of steel reinforcement (Fe 500/Fe 500D, TMT bars) for R.C.C. work including supply, straightening, cutting, bending, placing in position and binding with 16 gauge wire, all complete as per specification and direction of Engineer-In-Charge.	Kg	370.495		
7	Providing and fixing 18 mm thick gang saw cut, mirror polished, premoulded and prepolished, machine cut for kitchen platforms, vanity counters, window sills, facias and similar locations of required size, approved shade, colour and texture laid over 20 mm thick base cement mortar 1:4 (1 cement : 4 coarse sand), joints treated with white cement, mixed with matching pigment, epoxy touch ups, including rubbing, curing, moulding and polishing to edges to give high gloss finish etc. complete at all levels. Granite approved shade(skirting)	Sqm	10.40		
8	Providing and applying white cement based putty of average thickness 1 mm, of approved brand and manufacturer, over the plastered wall surface to prepare the surface even and smooth complete.	Sqm	393.60		
9	Providing and applying one coat of water thinnable cement primer of approved brand and manufacture on wall surface : Water thinnable cement primer	Sqm	393.60		

Sl. No.	Description	Unit	Quantity	Rate (Rs.)	Amount (Rs.)
10	Wall painting with Plastic emulsion paint of approved brand and manufacture (two or more coats) of approved brand and manufacture and of required shade, to achieve even shade and colour, at all levels, all complete as per manufacturer's specification or direction of engineer in charge.	Sqm	520.21		
11	Painting Steel work with Deluxe Multi Surface Paint to give an even shade. Two or more coat applied @ 0.90 ltr/10 sqm over an under coat of primer applied @ 0.80 ltr/10 sqm of approved brand and manufacture	Sqm	79.38		
12	Providing and fixing M.S. grills of required pattern in frames of windows etc. with M.S. flats, square or round bars etc. including priming coat with approved steel primer all complete. Fixed to steel windows by fastner with necessary screws etc. complete.	Kg	635.00		
13	Structural steel work riveted, bolted or welded in built up sections, trusses and framed work, including cutting, hoisting, fixing in position and applying a priming coat of approved steel primer all complete.	Kg	220.00		
14	Providing and fixing galvanized colour coated 0.5 mm thick sheet roofing including vertical / curved surface fixed with polymer coated J or L hooks, bolts and nuts 8 mm diameter with bitumen and G.I. limpet washers or with G.I. limpet washers filled with white lead, including necessary overlapping of sheets complete (up to any pitch in horizontal/ vertical or curved surfaces), excluding the cost of purlins, rafters and trusses and including cutting to size and shape wherever required.	Sqm	15.30		

Sl. No.	Description	Unit	Quantity	Rate (Rs.)	Amount (Rs.)
15	<p>Providing and fixing in position collapsible steel shutters with vertical channels 20x10x2 mm and braced with flat iron diagonals 20x5 mm size, with top and bottom rail of T-iron 40x40x6 mm, with 40 mm dia steel pulleys, complete with bolts, nuts, locking arrangement, stoppers, handles, including applying a priming coat of approved steel primer.</p>	Sqm	18.64		
16	<p>Providing and fixing aluminium work for doors, windows, ventilators and partitions with extruded built up standard tubular sections/ appropriate Z sections and other sections of approved make conforming to IS: 733 and IS: 1285, fixing with dash fasteners of required dia and size, including necessary filling up the gaps at junctions, i.e. at top, bottom and sides with required EPDM rubber/ neoprene gasket etc. Aluminium sections shall be smooth, rust free, straight, mitred and jointed mechanically wherever required including cleat angle, Aluminium snap beading for glazing / paneling, C.P. brass / stainless steel screws, all complete as per architectural drawings and the directions of Engineer-in-charge.</p> <p>For fixed portion Anodised aluminium (anodised transparent or dyed to required shade according to IS: 1868, Minimum anodic coating of grade AC 15)</p>	Kg	40.00		

Sl. No.	Description	Unit	Quantity	Rate (Rs.)	Amount (Rs.)
17	For shutters of doors, windows & ventilators including providing and fixing hinges/ pivots and making provision for fixing of fittings wherever required including the cost of EPDM rubber / neoprene gasket required Anodised aluminium (anodised transparent or dyed to required shade according to IS: 1868, Minimum anodic coating of grade AC 15)	Kg	25.00		
18	Providing and fixing glazing in aluminium door, window, ventilator shutters and partitions etc. with EPDM rubber / neoprene gasket etc. complete as per the architectural drawings and the directions of engineer-in-charge. (Cost of aluminium snap beading shall be paid in basic item): With float glass panes of 4.0 mm thickness (weight not less than 10kg/sqm)	Sqm	10.50		
19	Providing and fixing aluminium window lock of suitable size as per approved brand and manufacturer.	Pair	3.00		
	Total Amount (Rs.)				

Note: Rate shall be inclusive of taxes (GST) etc.

The tender job will be awarded on overall L1 basis, not on individual item basis.

(Signature of tenderer with seal)

Name