



विद्यारत्नम् महच्छनम्

राजीव गाँधी पेट्रोलियम प्रौद्योगिकी संस्थान जायस, अमेठी,  
उ. प्र.

**RAJIV GANDHI INSTITUTE OF PETROLEUM TECHNOLOGY**

**Jais, Amethi (U.P.) – 229 304**

**Website: [www.rgpt.ac.in](http://www.rgpt.ac.in)**

**TENDER DOCUMENTS FOR FOOT OVER BRIDGE AT RGIPT JAIS CAMPUS**

**PART – A : TECHNICAL BID**

NOTICE INVITING TENDER NO. : RGIPT/JAIS/IWD/FOOT OVER/02/2021-22 DATED: 24/08/2021

Last Date & Time of Submission: 15/09/2021 (Wednesday) by 3:00 P.M

**RAJIV GANDHI INSTITUTE OF PETROLEUM TECHNOLOGY**  
**Jais, Amethi (U.P.) – 229 304**

Tender Documents for construction of foot over bridge at RGIPT Jais campus.

<b>TABLE OF CONTENTS</b>		
<b>Sl. No.</b>	<b>Description</b>	<b>Page No.</b>
	<b>Technical Bid (Part A)</b>	
01.	Notice Inviting Tender	3 – 3
02.	Instructions To The Bidder	4 – 7
03.	General Terms & Conditions	8 – 15
04.	Scope of Work	16 – 16
05.	List of Approved Makes	16 – 16
06.	Drawings	17 – 19
07.	Annexure -1 (Technical Bid)	20 – 20
08.	Annexure - 2 (Details of work of similar nature)	21 – 21
09.	Annexure - 3 (Average Annual Financial Turnover)	22 – 22
10.	Annexure -4 (No Claim Certificate)	23 – 23
11.	Annexure -5 (No Conviction Certificate)	24 – 24
12.	Annexure -6 (Check List)	25 – 25
	<b>Price Bid (Part B)</b>	
13.	Price Bid	26 – 29

## Notice Inviting Tender

Rajiv Gandhi Institute of Petroleum Technology (RGIPT) invites sealed item rate tender under Two Part Bid System (Technical Bid and Financial Bid) from reputed, experienced and financially sound parties for construction of foot over bridge at RGIPT Jais Campus.

<b>Name of the Work</b>	Construction of foot over bridge at RGIPT Jais campus.
<b>Notice Inviting Tender No.</b>	Tender No: RGIPT/Jais/IWD/Foot Over/02/2021-22, Date- 24.08.2021
<b>EMD</b>	Rs. 10,000/- (Rupees Ten Thousand only) in the form of Demand Draft in favour of ' <b>Rajiv Gandhi Institute of Petroleum Technology</b> ' payable at ' <b>Jais</b> '.
<b>Work Completion Period</b>	The work completion period of contract shall be of 45 Days from date of issue of work order.
<b>Issue of Tender</b>	The Tender document link can be obtained from the institute's website – www.rgipt.ac.in & CPP Portal. Please keep visiting the website for any corrigendum /amendments and submit the bid documents accordingly.
<b>Last Date &amp; Time of Submission of Tender (Bid due date)</b>	Up to 3:00 P.M. on 15/09/2021 (Wednesday)
<b>Contact Person (for any clarification)</b>	Executive Engineer (Civil), e-mail: hkyadav@rgipt.ac.in, Mobile No.+91-9565993399
<b>Pre-Bid Meeting</b>	07/09/2021, 3:00 P.M. (Tuesday)
<b>Opening of Tender</b>	Part – A – Technical Bid Technical Bid will be opened on same day, i.e. 15 <sup>th</sup> September' 2021 at 04:00 P.M. in the presence of authorized representatives of the bidders at IWD office, Ground Floor of Hostel 'E' Block, RGIPT Jais, Amethi - 229304.
	Part – B – Financial Bid Financial Bid will be open for technically qualified bidders and shall be intimated for later date by the Institute.

## **INSTRUCTIONS TO BIDDERS**

1. Tenders on Item Rate (Unit Rate) basis are hereby invited under ‘Two Part Bid System’ i.e. Technical Bid and Financial Bid for Civil Work tender, under the heading “Construction of foot over bridge at RGIPT Jais campus.” at RGIPT Jais from reputed, experienced and financially sound Contractors of government departments/ Autonomous Bodies / National Level Institution / PSUs.

### **Eligibility Criteria**

The tenderers should have successfully completed similar works (Construction / Repair & Renovation of Building / Other Civil structures) during last seven years ending on 31<sup>st</sup> March, 2020 (31<sup>st</sup> March 2020 is considered because of loss of 1 year because of COVID Pandemic) should be either of the following: -

- a) Three similar completed works each of costing not less than the amount equal to Rs.1,50,000/- or
- b) Two similar completed works each of costing not less than the amount equal to Rs.1,80,000/- or
- c) One similar completed work each of costing not less than the amount equal to Rs.3,00,000/-.

The tenderers are required to produce proof of fulfilling these conditions (along with **Annexure-2** duly filled in) while submitting tender.

The Technical Bid should contain all the relevant information and desired enclosures in the prescribed format along with Earnest Money Deposit (EMD). The Price Bid should contain only the price Bid. In case, any bidder encloses the price (financial) bid within technical bid, the same shall be summarily rejected.

2. The total time for carrying out the work will be 45 days. The date of commencement shall be reckoned from the 7<sup>th</sup> day of issue of award letter/work order.
3. The Earnest Money Deposit (EMD) amounting to Rs.10,000/- only (Rupees Ten Thousand only) in the form of Demand Draft. The Demand Draft should be in favour of '**Rajiv Gandhi Institute of Petroleum Technology**' payable at '**Jais**'. Tender received without EMD will be invalid and rejected.
4. The bid security (EMD) shall be returned to the unsuccessful bidders after finalization of tender, without any interest.
5. Price bids of only those bidders will be opened, who qualify in the technical bids.
6. The Institute does not bind himself to accept the lowest or any tender and reserves to himself the right of accepting the whole or any part of the tender and the tenderer shall be bound to perform the same at the rates as quoted.
7. Canvassing in connection with the tenders is prohibited and the tenders submitted by the contractor who resort to canvassing are liable for rejection.
8. Tender submitted shall remain valid for 180 days from the date of opening for the purpose of acceptance and award of work.
9. Before tendering, the tenderer shall inspect the sites to fully acquaint himself about the condition in regard to accessibility of site, nature and extent of ground working condition of site and locally including stacking of materials, installation of tools and plants (T & P) etc., conditions affecting accommodations and movement of labour etc. required for the satisfactory

execution of the work contract. No claim whatsoever on such account shall be entertained by the Institute in any circumstances.

- 10.** If the contractor fails to commence the work as per Work Order then the Earnest Money will be forfeited.

**11. SECURITY DEPOSIT:**

- 11.1** The contractor shall be required to deposit an amount equal to 5% of the contract value as security deposit through Demand Draft in favour of “Rajiv Gandhi Institute of Petroleum Technology” payable at “Jais” within 10 days from the date of issuance of Work Order.

- 11.2** Security deposit shall be released to the contractor without interest after completion of all contractual obligations of the work based on ‘Completion Certificate’ issued by the competent authority and on submission of No Claim Certificate by the Contractor.

The security deposit shall be valid for a period of 60 (Sixty) days beyond the period of Defect Liability Period (DLP). If required, the EMD can be converted into security deposit after submission of written application and submission of balance amount by Demand Draft.

- 11.3** In case of termination of contract, the security deposit shall be forfeited.

- 12.** The pre-bid meeting will held at IWD Office on 07/09/2021 at 3:00 pm. The minutes of the said pre-bid meeting, if any, will be uploaded on RGIPT website for proper circulation. The bidders are therefore, requested to kindly check the RGIPT website before submission of their tender document.

- 13.** To acquaint themselves with the work, all the bidders are requested to visit the site on any working day (Monday to Friday) between 11:00 Hrs. to 16:00 Hrs., from 30/08/2021 to 14.09.2021.
- 14.** RGIPT, Jais, Amethi reserve the right to accept or reject all or any bid/quotation without assigning any reason thereof.

# **GENERAL TERMS & CONDITIONS**

## **1) INTERPRETATION**

### **WORK OR WORKS:**

Shall mean all work or works define in schedule of quantities, specifications and such other work or works as the contractor may be entrusted with for carrying out under this contract.

### **INSTITUTE:**

Shall mean Rajiv Gandhi Institute of Petroleum Technology, Jais, Amethi.

### **ENGINEER:**

Shall mean the Engineer designated by the Institute to superintend and perform other duties as indicated in the contract.

### **CONTRACTOR:**

Shall mean the individual or firm or company, whether incorporated or not undertaking the work and shall include the legal personal representative or such individual or the persons composing such firms or company or the Successor of such firm or company and the permitted assignees of such individual or firm(s) or Company.

### **SITE:**

Shall mean the site of contract works including any buildings and erection thereon and any other land adjoining thereto (inclusive) as aforesaid allotted by the Institute or the Engineer-in-Charge for the contractors use.

## **2) SUBMISSION OF TENDER:**

Tenders should be submitted in sealed envelopes in two Parts separately, i.e. **“Technical bid” (Part-A)** and **“Price bid” (Part-B)**. Both the parts should be



further sealed in an envelope super-scribing NIT No. & Name of Work, Bidders Name & Address. The tender duly filled should be sent to either by courier /post or dropped in the tender box provided at IWD office, Ground Floor of Hostel 'E' Block, RGIPT Jais campus, Bahadurpur, Mukhatiya More, Harbanshganj, Near Jais Railway Station, Amethi – 229304 on or before by 15<sup>th</sup> September' 2021 till 15:00 Hrs. **No tender shall be accepted later than the time schedule specified.**

### **3) TECHNICAL BID (PART –A):**

To qualify in the Technical Bid the firm should have the minimum eligibility criteria; the firm in this regard should submit the following documents-

- a) Duly filled format of Technical Bid as per **Annexure “1” & Annexure “2”**.
- b) The bidder should be an Indian Registered Company under Companies Act 1956/ Proprietorship / Firm / Company of any of these. Copy of Certificate of Incorporation / Registration or any other relevant document, as applicable, should be submitted along with a copy of address proof Copy of constitution or legal status of the sole proprietorship / firm / company etc.
- c) Average Annual Financial Turnover during the last 3 years, ending 31<sup>st</sup> March 2020, should be at least 1,80,000/-.  
(Please submit Annual Report in **Annexure – 3**, as certified by Chartered Accountant (Balance Sheet and Profit & Loss Account) for the last 3 (three) financial year's i.e. From 2017-18, 2018-19 & 2019-20).
- d) The technical bid should be accompanied by EMD for bid security of the amount.
- e) Copy of Income Tax Return Filed Acknowledgement for last 3 (three) financial year's i.e. from 2017-18, 2018-19 & 2019-20) should be enclosed.
- f) Copy of PAN Card.
- g) Copy of GSTIN registration certificate.
- h) Copy of Bank Account details along with cancelled Cheque.
- i) No conviction certificate on company's letterhead.

**j)** The bidder must have adequate experience for execution of works in Central / State Government Department /Semi Government department/ PSU/ Autonomous bodies having completed one, two, or three similar works in last seven years, as mentioned in Para 1 of page no. 4 of this tender. Necessary supporting documents in support of similar works like copy of work orders and completion certificate must be submitted along with the offer.

**k) Entire NIT (except Price bid) duly signed & stamped by the bidder.**

#### **4) PRICE BID (Part –B):**

In this bid the bidder is required to quote his item rates in the BOQ attached in accordance with the scope of work, terms & conditions & technical specifications enclosed. The rates/price quoted by contractor should be all inclusive i.e. should include all material cost, labour, services, plant/machinery/tools & tackles, ladders & scaffolding required for work, freight, Insurance, Govt. duties & levies, taxes (GST), transport/cartage of materials/labour and all other expenses not specifically mentioned but reasonably implied. Nothing over and above these rates shall be payable to contractor. Further nothing extra in rates will be considered for any variations in tender quantities or due to any site difficulties. It is mandatory for bidder to quote all items rate as asked for in the BOQ/ PRICE schedule. Failure in not filling some item rates will lead to rejection of tender. The bidders should quote unconditional rates, neatly written without any overwriting and all pages should be duly signed & stamped.

#### **5) PRICE VARIATION:**

No escalation over and above items rates quoted by the bidder shall be paid during the execution of contract.

**6) COMPLETION TIME:**

The total time for carrying out the work will be 45 days. The date of commencement shall be reckoned from the 7<sup>th</sup> day of issue of award letter/work order. Time is the essence of the contract.

**7) EXTENSION OF TIME:**

7.1 If the contractor desires for extension of time in respect of completion of work, on the grounds of his having been unavoidably hindered in its execution or any other ground, he shall apply in writing to the Executive Engineer (Civil), on account of which he desires extension, as aforesaid, and the Executive Engineer (Civil) shall, in his opinion (which shall be final) reasonable grounds shown therefore and after having the approval of competent authority, authorize such extension of time if any, which may in his opinion be necessary or proper.

**8) PAYMENT TERMS & CONDITIONS:**

8.1 RGIPT will not pay any mobilization advance for the work. Progressive payment, if required on justified ground, subject to approval of competent authority, will be paid during the progress of the work on the basis of the actual work done, measured and approved by RGIPT.

8.2 Full and Final payment will be paid on the basis of the actual work done, measured and approved by RGIPT upon satisfactory completion of the work.

**9) DEFECT LIABILITY PERIOD:**

Defect Liability Period shall be 6 months from the date of completion of all contractual obligations of the work based on 'Completion Certificate' issued by the competent authority.

**10) LIQUIDATED DAMAGES:**

In case of delay in completion of the work, the contractor shall pay liquidated damages an amount equal to 0.5% of the contract value per week of delay subject to a maximum of 5% of contract value.

- 11) If any extra or substituted item appears in the work, contractor shall submit its rate analysis supported with documents which shall be approved by RGIPT. If required, RGIPT can make its own analysis based on DSR document of CPWD or based on market rates for determining item rate.
- 12) The quantities mentioned in the tender are approximate. The running payment shall be made on the basis of actual work executed. Variation in the quantities, if any, shall not break the contract.
- 13) The contractor shall normally have to make his own arrangement for storage of materials and staying of labours. No request for accommodation of labours, within the campus will be entertained under any circumstances. However, at the request of contractor, a space shall be allotted for storing of materials within the campus, depending upon the availability.
- 14) Samples of all materials and other articles required for use on the work shall be got approved from Engineer-in-Charge, RGIPT before the starting of work.
- 15) All material and article brought by the contractor to the site of work for use shall conform to the samples approved. Final decision to reject any material shall rest with the RGIPT.
- 16) Makes of various materials to be used by contractor will be according to the list of approved makes given. No other makes will be used by the contractor.
- 17) Contractor will be paid on the basis of actual measurement against each respective item.

- 18) Contractor will arrange proper ladders and staging (for working at higher levels) at his own cost and will take all safety measures like safety belts, extra labour to hold ladders/staging etc. If it is observed that work is proceeding without adequate safety precautions, work may be stopped by Engineer-In-Charge and in such cases, contractor will be solely responsible for delay and its consequences thereof.
- 19) During the time of construction of foot over bridge, the contractor has to ensure that there will not be any stoppage for any kind of movement, in the chak marg. Along with this, all the possible precaution, which are required to be taken for the safety of pedestrian/vehicular movement, are required to be taken, without any extra cost. No separate payment under any circumstances will be entertained on the account of said reason.
- 20) Detailed technical specification for construction of foot over bridge with respect to materials & workmanship and mode of measurements will be as per IS codes and CPWD specifications, unless mentioned otherwise.

**21) LABOUR LAWS:**

The contractor will abide by all the rules and regulations related to labour laws, accident, workmen compensation act, workmen insurance etc. This will be the sole responsibility of the contractor. RGIPT will not be a party at any stage in any of the disputes relating to the above. In case, RGIPT has to bear any expenditure due to non-conformance of the above provisions by the contractor, the same will be recovered from contractor's bills.

- 22) The contractor shall depute competent Engineer/Supervisor for day to day supervision, coordination, liaison and other works etc. The representative of the Contractor shall attend regular / required meetings to expedite the works and sort out difficulties, if any. The contractor shall be responsible for progress of work and

for hurdles, if any, during the progress of work which are attributable to the contractor.

- 23) Contractor will take due permission for entry of all his workmen in RGIPT. No unauthorized person will be allowed to work inside.
- 24) The contractor will provide for all necessary materials, tools, equipment, access ladders & scaffolding, measuring instruments and working consumables etc. needed for execution of the works. Safe custody of all such material will be contractor's sole responsibility. No extra charges will be paid for the same. Watch and Ward of all material till the system is taken over by RGIPT shall be the sole responsibility of the contractor and pilferage etc. shall be entirely to his account.
- 25) During execution of work, the contractor should follow all standard norms of safety measures/precautions as per relevant IS codes and CPWD specifications to avoid accidents/damages to man, machines and buildings, at his own cost. Contractor will have his own arrangement to escort the labour to the nearest hospital for treatment in case any injury happens to any worker during execution of work.
- 26) No material belonging to the contractor whether consumable or non-consumable should be brought inside the RGIPT campus, without proper entry at the Main Gate nor any material should be taken out without proper gate pass issued by the authorized representatives of the RGIPT.
- 27) During execution of the work, contractor should dispose off waste material on regular basis and should keep the area of work, properly cordoned off and neat & clean as far as possible. After completion of work, contractor should clear the site completely of all unwanted and junk material before submitting his final bill.

**28)** RGIPT will provide free water and electricity during execution of work at one point. The contractor has to make his own arrangements for supplying power and water from that point onwards as per his requirements.

**29) FORCE MAJEURE:**

Conditions beyond control of either parties like war, hostility, acts of public enemy, civil commotion, sabotage, serious loss or damage by fire, explosions, epidemics, strikes, lockouts or acts of God come under the legal concept of Force Majeure (FM). Delays in performance of contractual obligations under influence of FM conditions are condonable by the other party without any right to termination or damages, provided, notice of the happening of any such event is given by the affected party to the other within 30 (thirty) days from the date of occurrence. Works under the contract shall be resumed as soon as practicable after such event has come to an end or ceased to exist. However, if such event continues for a period exceeding 120 days, either party may at its option terminate the contract by giving notice to the other party.

## **SCOPE OF WORK**

The scope of work is construction of foot over bridge, which is meant to connect the two portions of campus. The resident of campus will use this foot over bridge to cross a pedestrian path, which is distributing the campus in 2 portions. The foot over bridge is to be constructed, on the basis of design, as annexed, with proper fixing, erection and final shape. The said construction should be complete in all respect with uniform application of primer and 2 or more coat of multi surface paint, of approved shade, for proper grace.

## **LIST OF APPROVED MAKES**

1. Cement: ACC, Birla, Ultratech, Mycem
2. Structural Steel : SAIL, TATA, JINDAL, KAMDHENU, RANA, APOLLO, BHUSHAN, VANSH DURA
3. Paint: ICI Dulux / Asian / Berger / Nerolac



# Drawings

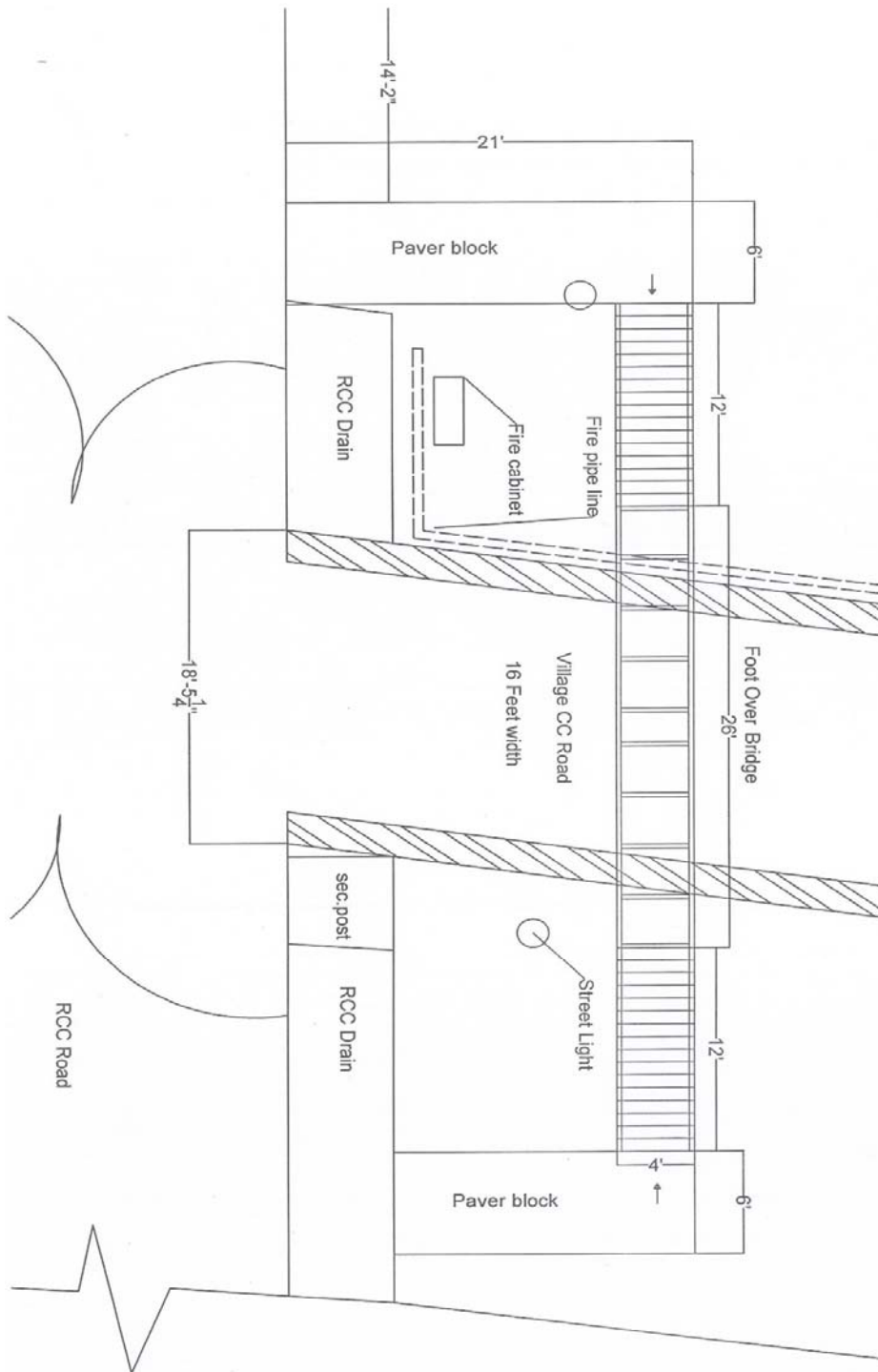

Rajiv Gandhi Institute of Petroleum Technology, Jais, Amethi

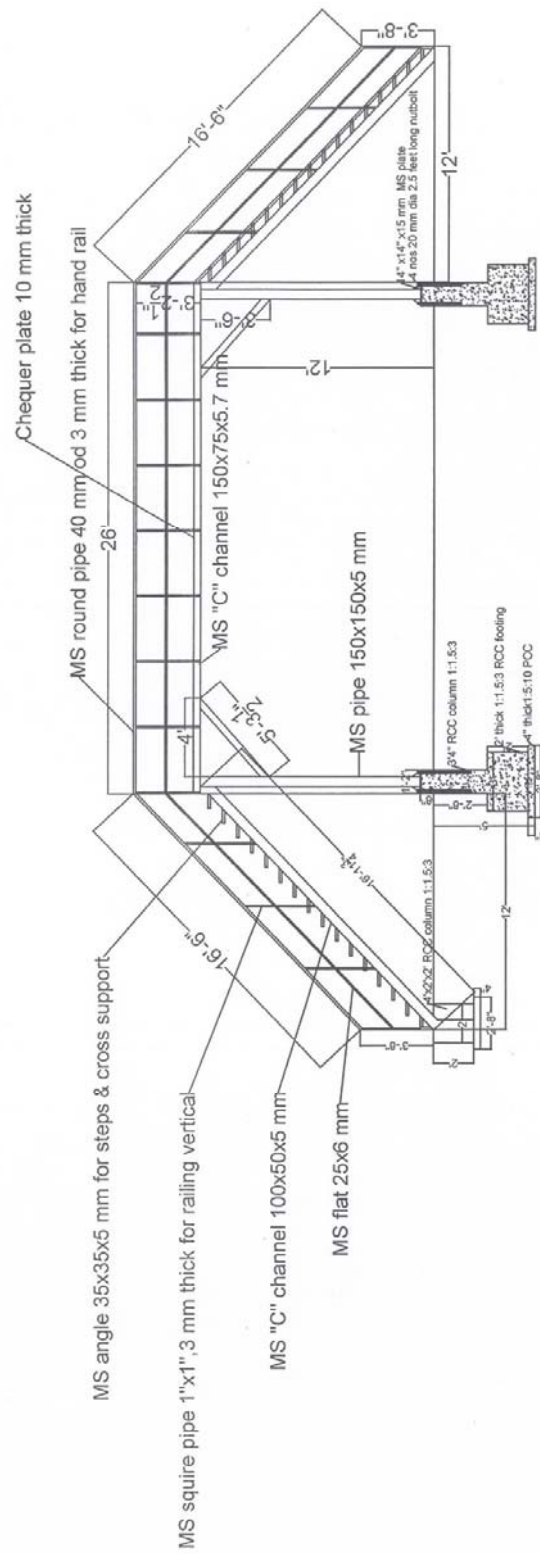

Sectional View of Foot Over Bridge

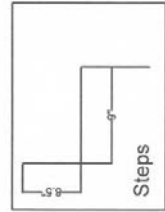

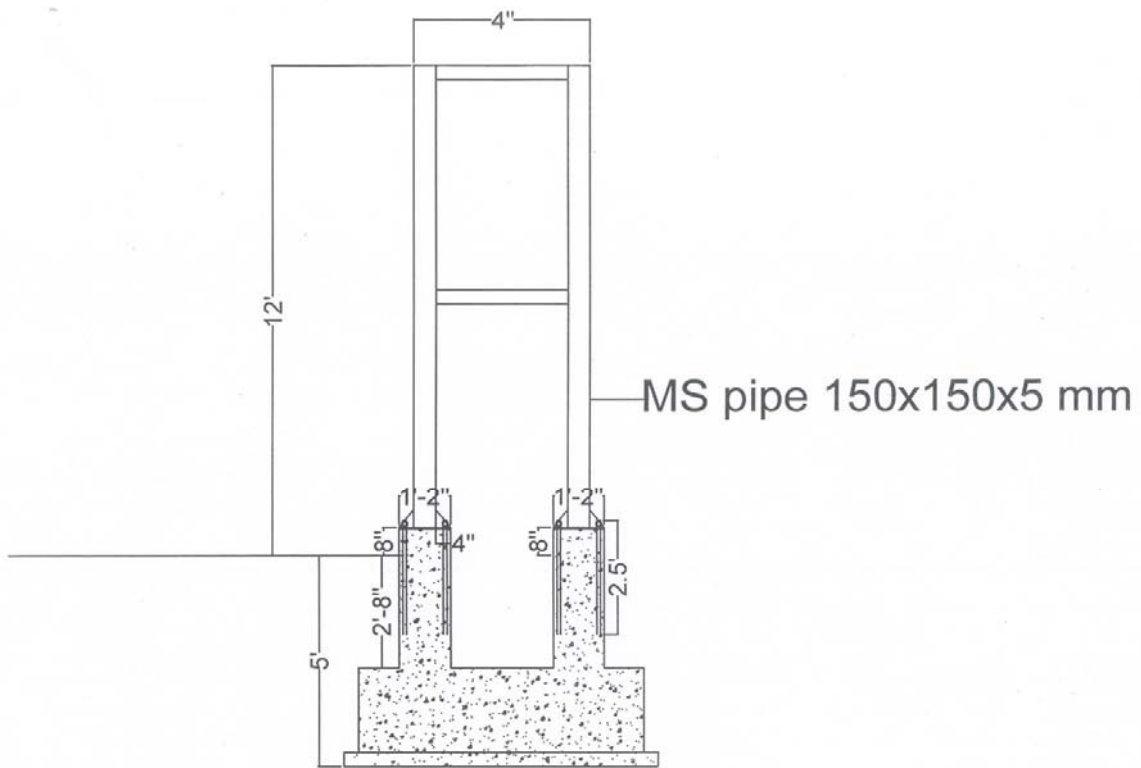

Section of Foundation

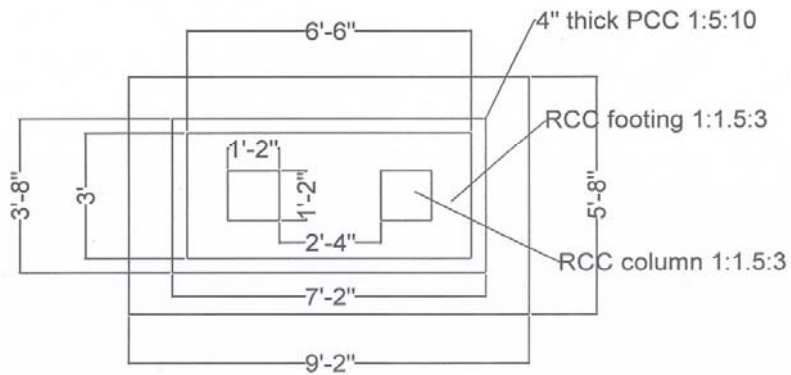

Foundation Plan of Foot Over Bridge

**TECHNICAL BID FORMAT**

<b>1</b>	Name of the firm/ Society/ Company/ Proprietary Concern (Attach self-attested copy)	
<b>2</b>	Address of registered office	
<b>3</b>	Telephone Nos./ Mobile Nos. /E-mail	
<b>4</b>	Earnest Deposits money (EMD) Yes/No	
<b>5</b>	PAN (Attach self-attested copy)	
<b>6</b>	Bank Account details	
<b>7</b>	GSTIN Registration No. (Attach self-attested copy)	
<b>8</b>	Details of clients along with address, telephone and Fax numbers, Amount of contract, Duration of contract. <b>(Attach a separate sheet in support of eligibility criteria).</b>	

(Signatures of the authorized signatory  
with seal of tendering firm)

**DETAILS OF WORK OF SIMILAR NATURE**

Details of similar work / order executed during last 7 years ending 31.03.2020 (Please submit copy of completion certificate from the client.

<b>S. No.</b>	<b>Name of Work</b>	<b>Authority under whom the work has been executed</b>	<b>Agreement / acceptance letter reference with date of issue</b>	<b>Value of work as per agreement/ acceptance</b>	<b>Date of actual completion of work / extended date of completion</b>	<b>Value of the work completed</b>	<b>Supporting Document</b>

**AVERAGE ANNUAL FINANCIAL TURNOVER**

Turnover of the Bidder for following 3 years (Please submit CA certified copy of Annual Reports)

<b>Year</b>	<b>Annual Report Submitted (Yes / No)</b>	<b>Turnover in Rs. (Lakh)</b>	<b>Profit/ Loss</b>
2017-2018			
2018-2019			
2019-2020			
<b>Total</b>			
<b>Average</b>			

**NO CLAIM CERTIFICATE**

(On company letterhead)

To,

(Contract Executing Officer)

Procuring Entity .....

Sub: Contract Agreement no. .... dated ..... for the work of..... We have received the sum of Rs..... (Rupees ..... only) in full and final settlement of all the payments due to us for the work of under the above-mentioned contract agreement, between us and Rajiv Gandhi Institute of Petroleum Technology. We hereby unconditionally, and without any reservation whatsoever, certify that with this payment, we shall have no claim whatsoever, of any description, on any account, against Procuring Entity, against aforesaid contract agreement executed by us. We further declare unequivocally, that with this payment, we have received all the amounts payable to us, and have no dispute of any description whatsoever, regarding the amounts worked out as payable to us and received by us, and that we shall continue to be bound by the terms and conditions of the contract agreement, as regards performance of the contract.

Yours faithfully,

Signatures

Name of Contractor or Officer Authorised  
to sign the contract documents on behalf of contractor  
(Company stamp)

Date: .....

Place: .....

**NO CONVICTION CERTIFICATE**

(On company letterhead)

This is to certify that \_\_\_\_\_ (Name of the organization), having registered office at \_\_\_\_\_ (Address of the registered office) has never been blacklisted or restricted to apply for any such activities by any Central / State Government Department /Semi Government department/ PSU/ Autonomous bodies or Court of law anywhere in the country.

Yours faithfully,

Signatures

Name of Contractor or Officer Authorised  
to sign the contract documents on behalf of  
Contractor

(Company stamp)

Date: .....

Place: .....



**Check List**

<b>Sl. No.</b>	<b>Particulars</b>	<b>Yes/No</b> <b>(Bidders to tick Yes/No)</b>
<b>1.0</b>	<b>Envelope 1 – Technical Bid (Part A)</b>	
<b>1.1</b>	EMD of Rs.10,000/- in the shape of D.D. in favour of ‘RGIPT’	<b>Yes / No</b>
<b>1.2</b>	Copy of constitution or legal status of the sole proprietorship / firm / company etc.	<b>Yes / No</b>
<b>1.3</b>	PAN No, GSTIN No., Bank Account details (Copy of Cancelled Cheque)	<b>Yes / No</b>
<b>1.4</b>	Copy of Income Tax Return Filed Acknowledgement	<b>Yes / No</b>
<b>1.5</b>	Copies of work order and completion certificates of works of similar nature (Annexure 1 & 2)	<b>Yes / No</b>
<b>1.6</b>	Copy of Annual Financial Turnover	<b>Yes / No</b>
<b>1.7</b>	Copy of No Conviction Certificate	<b>Yes / No</b>
<b>1.8</b>	Entire NIT (except Price Bid), other paper duly signed & stamped	<b>Yes / No</b>
<b>1.9</b>	Packet marked as Technical Bid (Part A) & sealed	<b>Yes / No</b>
<b>2.0</b>	<b>Envelope 2 – Price Bid (Part B)</b>	
<b>2.1</b>	BOQ (with quoted rate and amount of every item)	<b>Yes / No</b>
<b>2.2</b>	Each page signed & stamped by bidder	<b>Yes / No</b>
<b>2.3</b>	Packet marked as Price Bid (Part B) & sealed	<b>Yes / No</b>
<b>3.0</b>	<b>Envelope 3- Complete Tender (Part A + Part B)</b>	
<b>3.1</b>	Sealed envelopes contain two Parts separately, i.e. “Technical bid” (Part-A) and “Price bid” (Part-B).	<b>Yes / No</b>
<b>3.2</b>	Envelope super-scribing NIT No, name of work, bidders name & address.	<b>Yes / No</b>

**Note: - Entire NIT (except price bid) is to be attached with ‘Technical bid (Part-A)’ duly signed & stamped by the bidder.**



विद्यारत्नम् महच्छनम्

राजीव गाँधी पेट्रोलियम प्रौद्योगिकी संस्थान जायस, अमेठी,  
उ. प्र.

**RAJIV GANDHI INSTITUTE OF PETROLEUM TECHNOLOGY**

**Jais, Amethi (U.P.) – 229 304**

**Website: [www.rgipt.ac.in](http://www.rgipt.ac.in)**

**Tender Documents for foot over bridge at RGIPT Jais campus**

**PART – B : FINANCIAL BID**

NOTICE INVITING TENDER NO. : RGIPT/JAIS/IWD/FOOT OVER/02/2021-22 DATED: 24/08/2021

Last Date & Time of Submission: 15/09/2021 (Wednesday) by 3:00 P.M

Name of work – Construction of Foot over Bridge at RGIPT Jais campus.

**Bill of Quantity**

Sl. No.	Description	Unit	Quantity	Rate (Rs.)	Amount (Rs.)	Amount (Rs. In Words)
1	Earth work in excavation by mechanical means (Hydraulic excavator)/manual means over areas (exceeding 30 cm in depth, 1.5 m in width as well as 10 sqm on plan) including getting out and disposal of excavated earth lead upto 50 m and lift upto 1.5 m, as directed by Engineer-in-charge. All kinds of soil	cum	19.18			
2	Filling available excavated earth (excluding rock) in trenches, plinth, sides of foundations etc. in layers not exceeding 20cm in depth, consolidating each deposited layer by ramming and watering, lead up to 50 m and lift upto 1.5 m.	cum	14.76			
3	Providing and laying in position cement concrete of specified grade excluding the cost of centering and shuttering - All work up to plinth level : 1:5:10 (1 cement : 5 coarse sand (zone-III): 10 graded stone aggregate 40 mm nominal size)	cum	0.74			

Sl. No.	Description	Unit	Quantity	Rate (Rs.)	Amount (Rs.)	Amount (Rs. In Words)
4	Providing and laying in position specified grade of reinforced cement concrete, excluding the cost of centering, shuttering, finishing and reinforcement - All work up to plinth level : 1:1.5:3 (1 cement : 1.5 coarse sand (zone-III): 3 graded stone aggregate 20 mm nominal size)	cum	3.68			
5	Centering and shuttering including strutting, propping etc. and removal of form for : Foundations, footings, bases of columns, etc. for mass concrete	sqm	19.78			
6	Steel reinforcement for R.C.C. work including straightening, cutting, bending, placing in position and binding all complete upto plinth level. Thermo-Mechanically Treated bars of grade Fe-500D or more	kg	243.04			
7	Steel work welded in built up sections/ framed work, including cutting, hoisting, fixing in position and applying a priming coat of approved steel primer using structural steel etc. as required. In stringers, treads, landings etc. of stair cases, including use of chequered plate wherever required, all complete	kg	2857.62			

Sl. No.	Description	Unit	Quantity	Rate (Rs.)	Amount (Rs.)	Amount (Rs. In Words)
8	Finishing with Deluxe Multi surface paint system for interiors and exteriors using Primer as per manufacturers specifications: Painting Steel work with Deluxe Multi Surface Paint to give an even shade. Two or more coat applied @ 0.90 ltr/10 sqm over an under coat of primer applied @ 0.80 ltr/10 sqm of approved brand and manufacture	sqm	104.00			
	<b>Total Amount in figures &amp; words (Rs.)</b>					

**Note:** 1) Rate shall be inclusive of all taxes (GST), complete in all respect.

2) The tender job will be awarded on over L1 basis, not on individual item basis.

(Signature of tenderer with seal)

Name: