



RAJIV GANDHI INSTITUTE OF PETROLEUM TECHNOLOGY

[An Institute of National Importance established under an Act of Parliament]

Mubarakpur, Mukhetia, Bahadurpur Post: Harbanshganj, Jais, Amethi Pin Code- 229 304

Website: www.rgipt.ac.in

E-Procurement of Plasma Treatment Set up

Type of Tender	E-TENDER (OPEN)
E-Tender No.	RGIPT/JAIS/CEBE/E-OPN/LAB/2021-22/04 Dated: 15.02.2022
Item Description	Procurement of Plasma Treatment set up
Tender Type	<u>Composite Bid System</u> : Tender should be submitted on the schedule to tender. Composite Bid (Techno-Commercial Bid and Financial Bid will be opened on the same date and time)
Earnest Money Deposit (EMD)	Rs. 32,000/- (Rupees Thirty Two Thousand only) – Through online mode only.
Mode of Submission	Online Mode
E-Tender Date	15.02.2022
Pre-Bid Meeting date and time	23.02.2022 (Wednesday) 3:30 pm
Last date and time of submission of E-Tender	08.03.2022 (Tuesday) 3.00 pm
Date & Time of Opening of Composite bid	08.03.2022(Tuesday) 4.00 pm
Place of Opening of E-Tender	Institute of Conference Room, 2nd Floor, Administrative Building, Rajiv Gandhi Petroleum Technology, Jais, Amethi, UP
E-Tender Processing Fee (ITI Limited)	Rs. 750/- + (Applicable GST @18%) through e-payment Gateway available on https://rgipt.euniwizarde.com
Bid Address to	The Director Rajiv Gandhi Institute of Petroleum Technology, Mubarakpur, Mukhetia, Bahadurpur POST: Harbanshganj, Jais, Amethi – 229304
Chairman Purchase Committee	Name: Dr. Amit Ranjan Associate Professor, Chemical Engineering & Biochemical Engineering Email: aranjan@rgipt.ac.in Mobile No.8619286223, +91 535 270 4503 (LL)
Technical Clarification	Name: Dr. Amit Ranjan Associate Professor, Chemical Engineering & Biochemical Engineering Email: aranjan@rgipt.ac.in Mobile No. 8619286223, +91 535 270 4503 (LL)

The RGIPT, Jais, Amethi reserves the right to reject any or all the tenders without assigning any reason thereof and it is not binding on RGIPT, Jais, Amethi to accept the lowest bid or any other bid.

Tenders can be downloaded from www.rgipt.ac.in and <https://rgipt.euniwizarde.com/>

E Tendering Helpdesk Number: 011-49606060/8448288988/9650970101
E Tendering Helpdesk email ID ewizardhelpdesk@gmail.com,
ewizardhelpdesk89@gmail.com

INSTRUCTIONS FOR BIDDERS

The bidders are required to submit soft copies of their bids electronically on the e-tender Portal, using valid class 3 Digital Signature Certificates. The instructions given below are meant to assist the bidders in registering on the e-tender Portal, prepare their bids in accordance with the requirements and submitting their bids online on the e-tender Portal.

More information useful for submitting online bids on the e-tender Portal may be obtained at: <https://rgipt.euniwizarde.com>.

REGISTRATION

1. Bidders are required enroll on the e-Procurement Portal (URL: <https://rgipt.euniwizarde.com>) with clicking on the link "Online bidder Registration" on the e-tender Portal by paying the Registration fee of Rs. 2360/- Per vendor/per year.
2. As part of the enrolment process, the bidders will be required to choose a unique username and assign a password for their accounts.
3. Bidders are advised to register their valid email address and mobile numbers as part of the registration process. These would be used for any communication with the bidder.
4. Upon enrolment, the bidders will be required to register their valid Digital Signature Certificate (**Only Class III Certificates with signing + encryption key usage**) issued by any Certifying Authority recognized by CCA India (e.g. Sify / TCS / nCode / eMudhra etc.), with their profile.
5. Only one valid DSC should be registered by a bidder. Please note that the bidders are responsible to ensure that they do not lend their DSC's to others which may lead to misuse.
6. Bidder then logs in to the site through the secured log-in by entering their user ID /password and the password of the DSC / e-Token.
7. **The scanned copies of all original documents should be uploaded on portal <https://rgipt.euniwizarde.com>**

SEARCHING FOR TENDER DOCUMENTS

1. There are various search options built in the e-tender Portal, to facilitate bidders to search active tenders by several parameters.
2. Once the bidders have selected the tenders they are interested in, you can pay the form fee and processing fee (NOT REFUNDABLE) by net-banking / Debit / Credit card then you may download the required documents / tender schedules, Bid documents etc. Once you pay both fee tenders will be moved to the respective 'requested' Tab. This would enable the e- tender Portal to intimate the bidders through SMS / e-mail in case there is any corrigendum issued to the tender document.

PREPARATION OF BIDS

1. Bidder should take into account any corrigendum published on the tender document before submitting their bids.

2. Please go through the tender advertisement and the tender document carefully to understand the documents required to be submitted as part of the bid.
3. Bidder, in advance, should get ready the bid documents to be submitted as indicated in the tender document / schedule and generally, they can be in PDF formats. Bid Original documents may be scanned with 100 dpi with Colored option which helps in reducing size of the scanned document.
4. To avoid the time and effort required in uploading the same set of standard documents which are required to be submitted as a part of every bid, a provision of uploading such standard documents (e.g. PAN card copy, annual reports, auditor certificates etc.) has been provided to the bidders. Bidders can use “My Documents” available to them to upload such documents.
5. These documents may be directly submitted from the “My Documents” area while submitting a bid, and need not be uploaded again and again. This will lead to a reduction in the time required for bid submission process.

SUBMISSION OF BIDS

1. Bidder should log into the website well in advance for the submission of the bid so that it gets uploaded well in time i.e. on or before the bid submission time. Bidder will be responsible for any delay due to other issues.
2. The bidder has to digitally sign and upload the required bid documents one by one as indicated in the tender document as a token of acceptance of the terms and conditions laid down by RGIPT, Jais.
3. Bidder has to select the payment option as “e-payment” to pay the tender fee / EMD as applicable and enter details of the instrument.
4. Bidder should prepare the EMD as per the instructions specified in the tender document.
5. Bidders are requested to note that they should necessarily submit their financial bids in the format provided and no other format is acceptable. If the price bid has been given as a standard BOQ format with the tender document, then the same is to be downloaded and to be filled by all the bidders. Bidders are required to download the BOQ file, open it and complete the white Colored (unprotected) cells with their respective financial quotes and other details (such as name of the bidder). No other cells should be changed. Once the details have been completed, the bidder should save it and submit it online, without changing the filename. If the BOQ file is found to be modified by the bidder, the bid will be rejected.
6. The server time (which is displayed on the bidders’ dashboard) will be considered as the standard time for referencing the deadlines for submission of the bids by the bidders, opening of bids etc. The bidders should follow this time during bid submission.
7. All the documents being submitted by the bidders would be encrypted using PKI encryption techniques to ensure the secrecy of the data. The data entered cannot be viewed by unauthorized persons until the time of bid opening. Data storage encryption of sensitive fields is done. Any bid document that is uploaded to the server is subjected to symmetric encryption using a system generated symmetric key. Further this key is subjected to asymmetric encryption using buyers/bid opener public keys. Overall, the uploaded tender documents become readable only after the tender opening by the authorized bid openers.
8. The uploaded tender documents become readable only after the tender opening by the authorized bid openers.

9. Upon the successful and timely submission of bid click “Complete” (i.e. after clicking “Submit” in the portal), the portal will give a successful Tender submission acknowledgement & a bid summary will be displayed with the unique id and date & time of submission of the bid with all other relevant details.
10. The tender summary has to be printed and kept as an acknowledgement of the submission of the tender. This acknowledgement may be used as an entry pass for any bid opening meetings.

ASSISTANCE TO BIDDERS

1. Any queries relating to the tender document and the terms and conditions contained therein should be addressed to the Tender Inviting Authority for a tender or the relevant contact person indicated in the tender.
2. Any queries relating to the process of online bid submission or queries relating to e-tender Portal in general may be directed to the 24x7 Helpdesk Support. **The contact number for the helpdesk is “011-49606060/8448288988/9650970101” and E Tendering Helpdesk email ID: ewizardhelpdesk@gmail.com**

E-Procurement of Plasma Treatment Set up

Online Tenders from reputed Original Equipment Manufacturers/ Authorized Dealers for Plasma Treatment Set up are invited by the Rajiv Gandhi Institute of Petroleum Technology, Amethi- 229 304 in **Composite Bid System** as per specifications mentioned below:

ITEM PARTICULARS

Tender No: - RGIPT/JAIS/CEBE/E-OPN/LAB/2021-22/04

Date: 15.02.2022

Technical Specification for Plasma Treatment Set up

A custom designed plasma treatment chamber along with pumps and gauges, and an additional assembly to introduce liquid to submerge the sample is desired to be fabricated. The details of the design and its necessary components are given hereunder:

Sr. No	Description	Qty.
1	chamber with top flange, plasma electrode, valves, liquid inlet valve and related arrangement etc mounted on a small mounting table	1
2	Rotary pump 9 m ³ /hr , magnetically coupled, low noise rotary pump with the following specs I. Pumping speed: 9 m ³ /hr or better II. Ultimate pressure with gas ballast: 10 ⁻² bar or better III. Water vapor capacity: 210 g/h or better ar 50 Hz IV. Magnetically couples V. Rotation speed at 50 Hz: 1500 RPM VI. Low noise. Emission sound level without gas ballast: 57 dB or less VII. Weight: 30 kg or less VIII. Leak rate safety valve: 10 ⁻⁴ mba l/s or better. IX. One year warranty	1
3	Capacitance gauge: 0 to 10 torr	1
4	Throttle valve with connecting hardware for pump	1
5	Needle valve for gas inlet to control the plasma	1
6	Plasma power supply (pulse DC, 40 kHz, 1kW) with following technical specs: I. Power output 1 kW or better II. Max bias voltage 1000 V or better. III. Frequency: 40 kHz if fixed or better (variable frequency) IV. The power supply is a negative pressure pulsed DC power supply (Negative of the power supply can be used for biasing and positive to be connected to the grounded vacuum chamber). V. To be remotely controlled by analog voltage signals (for turning power supply ON and OFF, setting bias voltage and for measuring ionization current). VI. One year warranty	1
7	The manufacturer should have long experience in fabrication of custom made instruments and must have provided custom-made assemblies to IITs, IISERs, and leading national labs.	

Detail design of the assembly:

The overall unit:

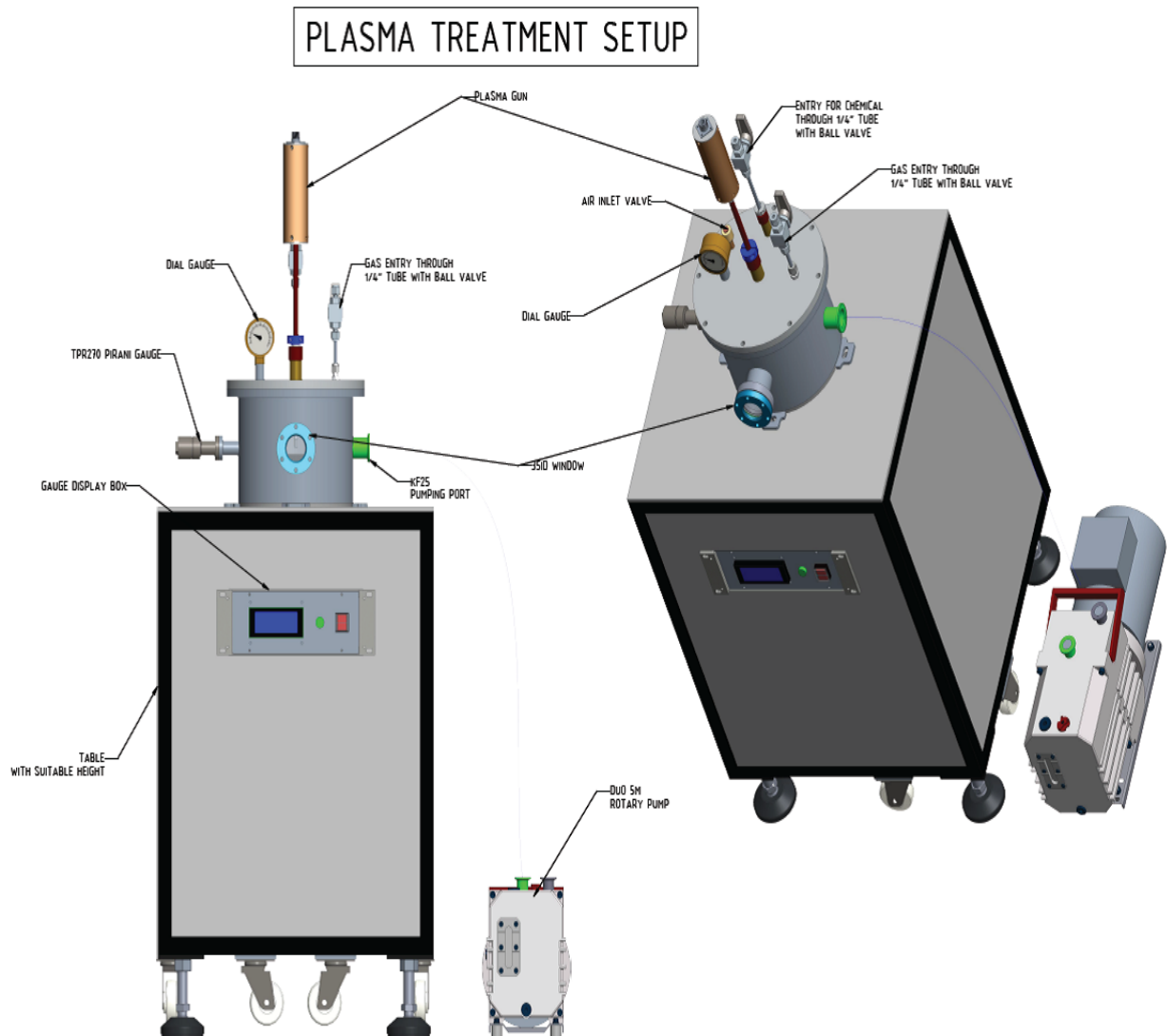

The main chamber:

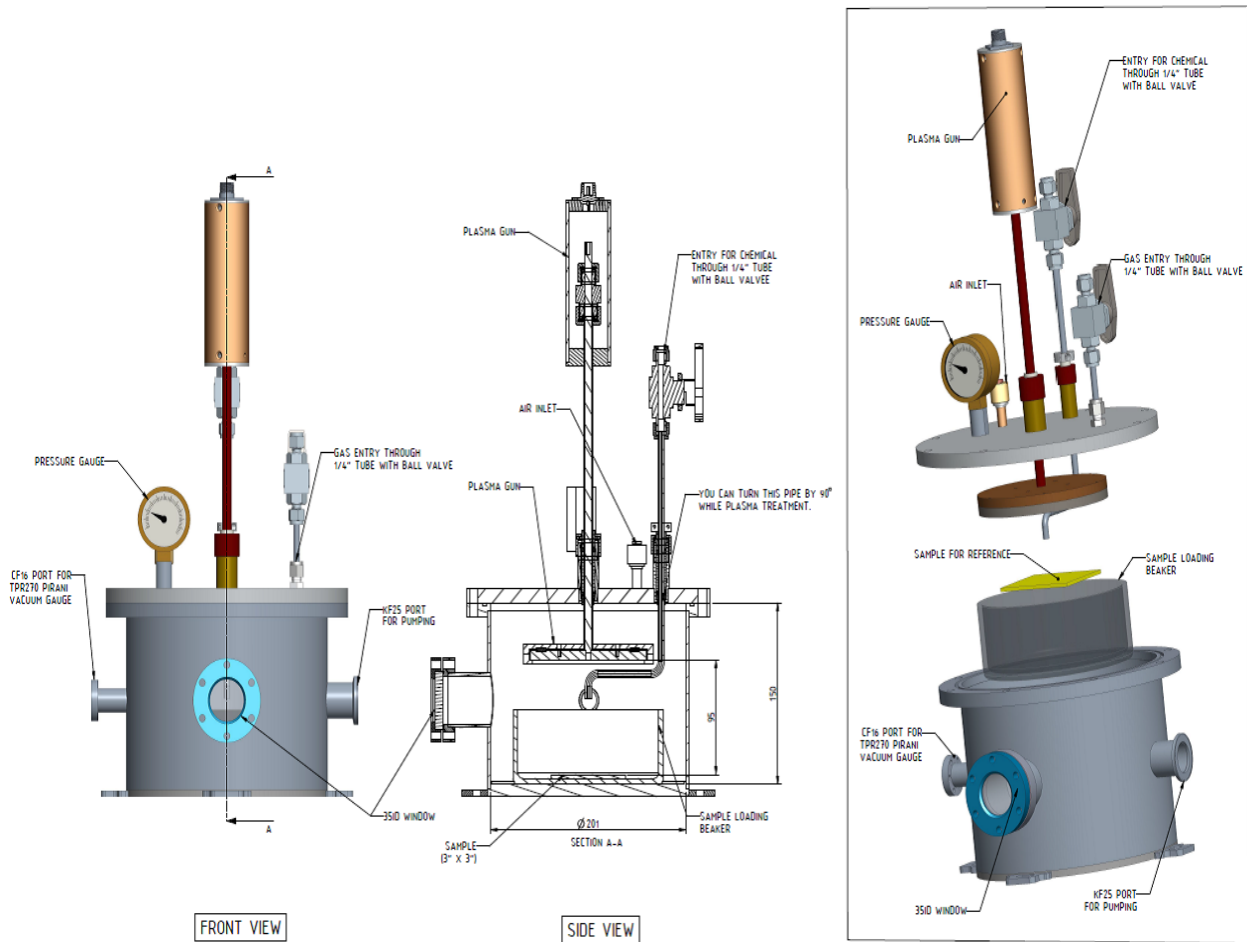

Place:

Date:

Signature and seal of the Manufacturer/ Bidder

Technical Specifications Compliance Statement of “Plasma Treatment Set up” should be submitted as per format given in Annexure – I (On the Company’s Letter Head)

Terms & Conditions

1. Tender filling up and submission

- a. Tender offer must refer to the letter/Notice inviting the Tender.
- b. The bid should be uploaded online mentioning “Supply & Installation **“Plasma Treatment Set up”** to Rajiv Gandhi Institute of Petroleum Technology, Jais, Amethi.
- c. Bids must be submitted online against above mentioned tender.
- d. **Please quote costs of individual components from items 1 to 6 listed in the Technical Specifications.**
- e. The prices can be quoted INR/FOREIGN CURRENCY in figures and in words and the same will be considered for price comparison. Where there is a difference between the two, the rates given in words will be taken as authentic. Should there be any discrepancy between unit rate and amount; the unit rate will be considered as the correct one.
- f. The rates quoted should include freight charges up to Jais, Amethi clearly mentioning the percentage/rate of GST and the rates quoted should be valid for at least 60 days from the date of opening of the quotation. The rates must be quoted both in figures and words and overwriting should be avoided. However all cuttings/corrections must be duly authenticated.
- g. The bid submitted must not contain any ambiguity. Any such ambiguity in the quote submitted shall make it liable for rejection.
- h. The tender document is not transferable.
- i. No amendment to the bid in any form by the bidder will be permitted after opening of the tender. No conditional offers shall be accepted.
- j. Submission of bid will bind the bidder to the acceptance of all conditions specified in the tender document.
- k. Canvassing in any form is for bidden and will be a criterion for disqualification.
- l. **Price bid submission for imported equipment:** In case of imported equipment, price (quote) shall be in two parts –(a) CIF –(Cost, Insurance, Freight) price up to Airport in Foreign currency, and
(b) From Airport to destination (RGIPT, Jais, Amethi) in Indian currency. The components covered in this schedule consist of custom duty; custom clearance charges; freight charges, & Installation and training charges etc, which will be reimbursed in Indian currency to the Indian counterpart as per actual (Up to the maximum limit quoted in the bid), on submission of the original supporting bills duly certified and stamped by the Chairman Purchase Committee.
- m. The Purchase Order (PO) to import any equipment shall be placed on the name of ‘foreign principal’ only in foreign currency.
- n. A principal manufacturer of the equipment can submit only one bid either themselves or through their authorized channel partner.

2. Special Instructions:

- i. Non-receipt of quote in foreign currency for imported equipment may lead to the rejection of their bid without assigning any reason thereof.
- ii. RGIPT shall provide custom/excise duty exemption certificate and GST exemption certificate on request by the bidder.
- iii. RGIPT, Jais, Amethi avails custom duty exemption in terms of Government Notification

No. 51/96-Customs dated 23 July, 1996, and Central Excise Duty Exemption in terms of Government Notification No. 10/97-Central Excise dated 01 March, 1997, as amended time to time.

- iv. RGIPT, Jais, Amethi avails GST concession under notification No. 47/2017 central tax (rate) dated 14 November 2017, as amended time to time.
- v. The earnest money deposit (EMD)/ bid security shall be submitted in Indian currency only. The bid security should remain valid for a period of 45 days beyond the final bid validity period.
- vi. The company before the opening of letter credit (LC) or wire transfer shall submit the performance security. The company shall submit the performance security at the rate of three percent (3%) of contract in Indian Rupees in the form of demand draft/FDR/PBG, issued in the favor of “Rajiv Gandhi Institute of Petroleum Technology” payable at bank of Baroda, RGIPT of the schedule bank.
- vii. The performance guarantee should remain valid at least for a period of 60 days of beyond the date of completion of all contractual obligations of supplier.
- viii. The eighty percent (80%) payment of contract value shall be paid at site by an irrevocable letter of credit, two weeks prior to dispatch of equipment on submission of original documents without any discrepancies and balance twenty percent (20%) shall be released after satisfactory installation and commissioning of equipment.

3. **EMD (Earnest Money Deposit): The EMD should pay only in online mode on <https://rgipt.euniwizarde.com> Rs. 32,000/- (Rupees Thirty Two Thousand only) – Through online mode only). No interest shall be paid on earnest money deposited.**

- a) The EMD of the unsuccessful bidders will be returned after final award of the Job to a successful bidder/ acceptance of the tender and within reasonable time not exceeding six months from the date of opening of Tender. The EMD will carry no interest.
- b) The EMD will be forfeited if the bidder withdraws his offer before finalization of the tender.
- c) The EMD of successful bidder will be returned after the submission of Performance Security.
- d) The firms registered with DGS&D, MSME & NSIC, if any, are exempted from payment of EMD provided such registration includes the item they are offering which are manufactured by them and not for selling products manufactured by other companies. **(Latest Copy must be submitted online for claiming exemption).**

4. **Performance Security: The successful bidder will provide “Performance Security” for an amount of 3% of the contract value in the form of valid Account payee Demand Draft/FDR from a scheduled bank favoring “Rajiv Gandhi Institute of Petroleum Technology” payable at RGIPT, Jais, Amethi Campus Branch. Performance security should remain valid at least for a period of 60 days beyond the date of completion of all contractual obligations of supplier (Total Period of FDR/Demand Draft – Warranty Period plus 60 days). Thereafter the security will be returned, provided there is no defect in the equipment supplied.**

5. **Evaluation Criteria:** The order will be awarded to the vendor, who fulfills all the technical specifications & conditions mentioned in the tender document for Technical Bid and whose rate is L1 in grand total in Financial Bid. Evaluation of Lowest bid will be calculated on the total price of all items tendered for basic equipment along with accessories, packing & forwarding, Installation & Commissioning, GST and other charges etc. as mentioned in the tender (Bidder must submit the technical bid & financial bid separately).
6. **Bid Validity:** The bid must be valid for 180 days from the date of opening of Technical Bid.
7. **Payment terms:**
 - a) **In Indian Currency Payment terms** – 80% payment will be released against successful supply of equipment at site i.e Rajiv Gandhi Institute of Petroleum Technology, Jais, Amethi and balance 20% after installation & commissioning of the equipment and subject to submission of original Bill/ Invoice as certified by the Indenter.
 - b) **In Foreign currency payment** -80% payment by an irrevocable letter of credit favouring Principal Company and for compliance of payment term, two weeks prior to dispatch of the equipment on submission of letter from Principal Company confirming that the equipment is ready for dispatch and on receipt of documents without any discrepancies and balance 20% will be paid after satisfactory installation and commissioning as certified by the indenter.
 - c) **Reimbursement of Expenses in Indian Rupees:** The Institute will reimburse the expenses in Indian Rupees related to custom duty, custom clearance charges, transportation charges upto RGIPT, Jais, Amethi to the Indian Counterpart after the installation and commissioning of equipment at site (Upto maximum limit defined in the bid) i.e Rajiv Gandhi Institute of Petroleum Technology, Jais, Amethi – 229304 and subject to submission of original bill certified by the Indenter.
8. **Clearance and delivery:** On arrival of shipment/consignment, the supplier is required to arrange custom clearance and transportation of the consignment up to RGIPT, Jais, Amethi premises. The Tenderer/ bidder will do all types of clearance work and formalities to deliver/provide the equipment at the site of installation. The expenses incurred will be reimbursed on actual basis not exceeding the quoted amount. Institute will provide all types of documentary support including Customs Duty exemption certificate. The custom duty, custom clearance charges, transportation charges etc. will be reimbursed in Indian Rupees on subject of submission of documentary proof. This may be included in your quotation as a separate item. Principals will themselves have to procure any requisite permission from the Govt. of country of origin of equipment.
9. **Part Shipment not allowed:** Part Shipment will NOT be allowed.
10. **Insurance:** For delivery of goods at the purchaser's premises, the insurance shall be obtained by the supplier in an amount equal to 110% of the value of the goods from "warehouse to warehouse" (final destinations) on "All Risks" basis including War Risks and Strikes. The insurance shall be valid for a period of not less than 3 months after

installation and commissioning. If orders placed on CIF/CIP basis, the insurance should be up to RGIPT, Jais, Amethi.

11. **Bank Charges:** All the bank charges within India will be borne by the Institute and outside India will be borne by the Supplier.
12. **Site Preparation:** The supplier shall inform to the Institute about the site preparation, if any, needed for the installation of equipment, immediately after the receipt of the purchase order. The supplier must provide complete details regarding space and all the other infrastructural requirements needed for the equipment, which the Institute should arrange before the arrival of the equipment to ensure its timely installation and smooth operation thereafter. The supplier shall visit the Institute and see the site where the equipment is to be installed and may offer his advice and render assistance to the Institute in the preparation of the site and other pre-installation requirements.
13. **Resolution of Disputes:** The dispute resolution mechanism to be applied pursuant shall be as follows:
 - i. In case of Dispute or difference arising between the Purchaser and a domestic supplier relating to any matter arising out of or connected with this agreement, such disputes or difference shall be settled in accordance with the Indian Arbitration & Conciliation Act, 1996, the rules there under and any statutory modifications or re-enactments thereof shall apply to the arbitration proceedings. The dispute shall be referred to the Director, Rajiv Gandhi Institute of Petroleum Technology, Jais, Amethi and if he is unable or unwilling to act, to the sole arbitration of some other person appointed by him willing to act as such Arbitrator. The award of the arbitrator so appointed shall be final, conclusive and binding on all parties to this order.
 - ii. In the case of a dispute between the purchaser and a Foreign Supplier, the dispute shall be settled by arbitration in accordance with provision of sub-clause (a) above. But if this is not acceptable to the supplier then the dispute shall be settled in accordance with provisions of UNCITRAL (United Nations Commission on International Trade Law) Arbitration Rules.
The venue of the arbitration shall be the place from where the order is issued.
14. Live working product Demo of same or similar item is necessary (at the cost of bidder) for all the bidders, if asked for, within the ONE week of opening the technical bid.
15. **Printed Conditions of the Company – Not Acceptable to the Institute:** RGIPT does not accept the printed conditions of any Tenderer. It will be ignored without any reference; hence tenderers should withdraw such printed conditions if they have any. RGIPT shall accept only unconditional tender.
16. **Technical Deviations – Sole discretion of RGIPT for consideration:** If technical deviations furnished by the Tenderer are not agreeable to RGIPT, the offers may be ignored. However it will be solely at discretion of RGIPT to consider the technical deviations OR not for considering the Tenderer. No correspondences of the Tenderer will be entertained in this matter.

17. **Price Validity:** The price quoted by the bidder shall remain valid till the supply is completed. During the tenure of the supply period, no price increase will be considered, except for change in statutory levies imposed by Centre Govt. / state Govt. or Local authorities.
18. **Warranty:** As mentioned in technical specification.
19. **Delivery:** The timely delivery of “**Plasma Treatment Set up**” is the essence of contract. The supply should be completed with the specified delivery. Delivery shall be completed within maximum 16 weeks from the placement of purchase order/from the date of opening of LC.
20. **Bid Acceptance and Rejection:**
 - i. RGIPT reserves the right to reject the bid without assigning any reason what so ever.
 - ii. RGIPT does not bind itself to accept the lowest or any quotation and reserves the right to reject any or all without assigning any reason.
21. **Late Receipt of Bids:** No bids will accepted or considered after the due date and time.
22. **Liquidity Damage Clause:** In case of any damages and delay in supply of material, liquidated damages at the rate of 0.5% of the order value per day of delay or part thereof, subject to a maximum of 5% of the order value shall be recovered from the vendor’s bill/invoice.
23. **Withdrawal of Tender:** The Institute reserves the right to withdraw the tender at any stage of tendering process with the approval of the Competent Authority.
24. **Replacements of Goods Broken, Damaged or Short:** If whole or part of the goods/ equipment supplied against the order is found defective/ non-functional or without specification the supplier will have to replace the defective goods/equipment to make equipment operational within a reasonable time (not exceeding two months from the date of intimation to the supplier or the Indian Agent), failure to which the supplier will have to refund the full cost of the equipment including freight, Insurance etc.
25. A quotation submitted with false information will not only be rejected but the vendor may also be debarred for participation in future tendering processes.
26. Authorized representative may choose to be present at the time of opening of quotation at their own cost.
27. Each bidder should have at least 3 years performance of supplying the **Plasma Treatment Set up** in various IIT/NIT/Other National Level Institutes in India. Purchase Order copy should be attached.
28. **Only on Price Bid should be submitted for the above equipment. A bidder who submits more than one Price Bid, shall be disqualified and considered non-responsive.**

Sd/-

Chairman Purchase Committee

Documents required for eligibility in the tender

Sl. No.	Description
	The EMD of Rs. 32,000/- (Rupees Thirty Two Thousand only) is to be paid only through online mode on https://rgipt.euniwizarde.com . If the EMD is not paid, then the bid will be automatically rejected.
1	Technical Specification Compliance Statement -(On the letter head of the Company) - Annexure -1
2	Manufacturer's Authorization Form – In defined format OR Self Declaration of Manufacturing Unit – Annexure – 2
3	Price Reasonability Certificate – In defined format (On the letter head of the Company)- Annexure – 3
4	Declaration Certificate (Acceptance of terms & conditions of the tender) – In defined format (On the letter head of the Company) - Annexure – 4 and Declaration Sheet as per Annexure - 4A .
5	As on date of submission of the proposal, the Bidder is neither blacklisted by Central Government/ State Government or Instrumentalities thereof nor is any criminal case against the Bidder/ its Partners/ Directors/ Agents pending before any court of law. Non-Blacklisting Certificate on Rs. 100.00 non-Judicial Stamp Paper – In defined format - Annexure – 5
6	Copy of Firm Registration
7	Copy of PAN Card & GST No.
8	Bidder should have at least 3 years' experience in the selling and providing service/maintenance for Plasma Treatment Set up to reputed Central Government Institutes/Engineering Colleges/ Universities/ Oil Companies/PSUs/Research Institutes/ IITs/ NITs/ IISERs (Self Declaration) – List of Clients & Purchase Orders of “Plasma Treatment Set up” to be submitted.
9	Bidder should enclose the copies of last 3 years Audited Annual Accounts (Balance Sheet and Profit & Loss A/c) duly authenticated by Chartered Accountant
10	Last three years CA certified turnover certificate (Average Turnover of last three years should not be less than Rs. 4.00 Lakh (Rupees Four Lakh only))
11	Last 3 year Income Tax Return (ITR)
12	In case of exemption of EMD, the scanned copy of the document in support of exemption will have to be uploaded by the bidder during bid submission
13	MOST IMPORTANT: Document related to prior installation and service – At least 3 Academic and R&D National Organizations, Central and State Government Departments/ Institutions/ PSU in the last 3 years. Annexure - 6



RAJIV GANDHI INSTITUTE OF PETROLEUM TECHNOLOGY

**CHECKLIST FOR SUBMISSION OF DOCUMENTS FOR
TECHNO-COMMERICAL BID**

Part -1

MOST IMPORTANT: PLEASE DON'T ADD OR UPLOAD ANY ANNEXURE OF PRICE BID IN TECHNO-COMMERICAL BID DOCUMENTS, OTHERWISE YOUR BID WILL BE REJECTED.

Checklist for submission of documents for Techno-Commercial Bid

Sl. No.	Description	Uploaded/ Not Uploaded
	The EMD of Rs. 32,000/- (Rupees Thirty Two Thousand only) is to be paid only through online mode on https://rgipt.euniwizarde.com . If the EMD is not paid, then the bid will be automatically rejected.	
1	Technical Specification Compliance Statement - (On the letter head of the Company) - Annexure - 1	
2	Manufacturer's Authorization Form - In defined format OR Self Declaration of Manufacturing Unit - Annexure - 2	
3	Price Reasonability Certificate - In defined format (On the letter head of the Company)- Annexure - 3	
4	Declaration Certificate (Acceptance of terms & conditions of the tender) - In defined format (On the letter head of the Company) - Annexure - 4 and Declaration Sheet as per Annexure - 4A .	
5	As on date of submission of the proposal, the Bidder is neither blacklisted by Central Government/ State Government or Instrumentalities thereof nor is any criminal case against the Bidder/ its Partners/ Directors/ Agents pending before any court of law. Non-Blacklisting Certificate on Rs.100.00 non-Judicial Stamp Paper - In defined format - Annexure - 5	
6	Copy of Firm Registration	
7	Copy of PAN Card & GST No.	
8	Bidder should have at least 3 years' experience in the selling and providing service for Plasma Treatment Set up to reputed Central Government Institutes/Engineering Colleges/ Universities/ Oil Companies/PSUs/Research Institutes/ IITs/ NITs/ IISERs (Self Declaration) - List of Clients & Purchase Orders of " Plasma Treatment Set up " to be submitted.	
9	Bidder should enclose the copies of last 3 years Audited Annual Accounts (Balance Sheet and Profit & Loss A/c) duly authenticated by Chartered Accountant	
10	Last three years CA certified turnover certificate (<u>Average Turnover of last three years should not be less than Rs. 4.00 Lakhs (Rupees Four Lakh only)</u>)	
11	Last 3 year Income Tax Return (ITR)	
12	In case of exemption of EMD, the scanned copy of the document in support of exemption will have to be uploaded by the bidder during bid submission	
13	MOST IMPORTANT: Document related to prior installation and service - At least 3 Academic and R&D National Organizations, Central and State Government Departments/Institutions/PSU in the last 3 years. Annexure - 6	

Place:

Date:

Signature and seal of the Manufacturer/ Bidder

Technical Compliance Statement for Plasma Treatment Set up**(ON THE LETTER HEAD OF THE COMPANY)**

A plasma treatment chamber along with pumps and gauges, and an additional assembly to introduce liquid to submerge the sample is desired to be fabricated. The details of the design and its necessary components are given hereunder:

Sr No	Description	Qty.	Comply/Not Comply
1	chamber with top flange, plasma electrode, valves, liquid inlet valve and related arrangement etc mounted on a small mounting table	1	
2	Rotary pump 9 m ³ /hr , magnetically coupled, low noise rotary pump with the following specs	1	
	I. Pumping speed: 9 m ³ /hr or better		
	II. Ultimate pressure with gas ballast: 10 ⁻² bar or better		
	III. Water vapor capacity: 210 g/h or better ar 50 Hz		
	IV. Magnetically couples		
	V. Rotation speed at 50 Hz: 1500 RPM		
	VI. Low noise. Emission sound level without gas ballast: 57 dB or less		
	VII. Weight: 30 kg or less		
	VIII. Leak rate safety valve: 10 ⁻⁴ mba l/s or better.		
	IX. One year warranty		
3	Capacitance gauge: 0 to 10 torr	1	
4	Throttle valve with connecting hardware for pump	1	
5	Needle valve for gas inlet to control the plasma	1	
6	Plasma power supply (pulse DC, 40 kHz, 1kW) with following technical specs:	1	
	I. Power output 1 kW or better		
	II. Max bias voltage 1000 V or better.		
	III. Frequency: 40 kHz if fixed or better (variable frequency)		
	IV. The power supply is a negative pressure pulsed DC power supply (Negative of the power supply can be used for biasing and positive to be connected to the grounded vacuum chamber).		
	V. To be remotely controlled by analog voltage signals (for turning power supply ON and OFF, setting bias voltage and for measuring ionization current).		
	VI. One year warranty		
7	The manufacturer should have long experience in fabrication of custom made instruments and must have provided custom-made assemblies to IITs, IISERs, and leading national labs.		

Detail design of the assembly:

The overall unit:

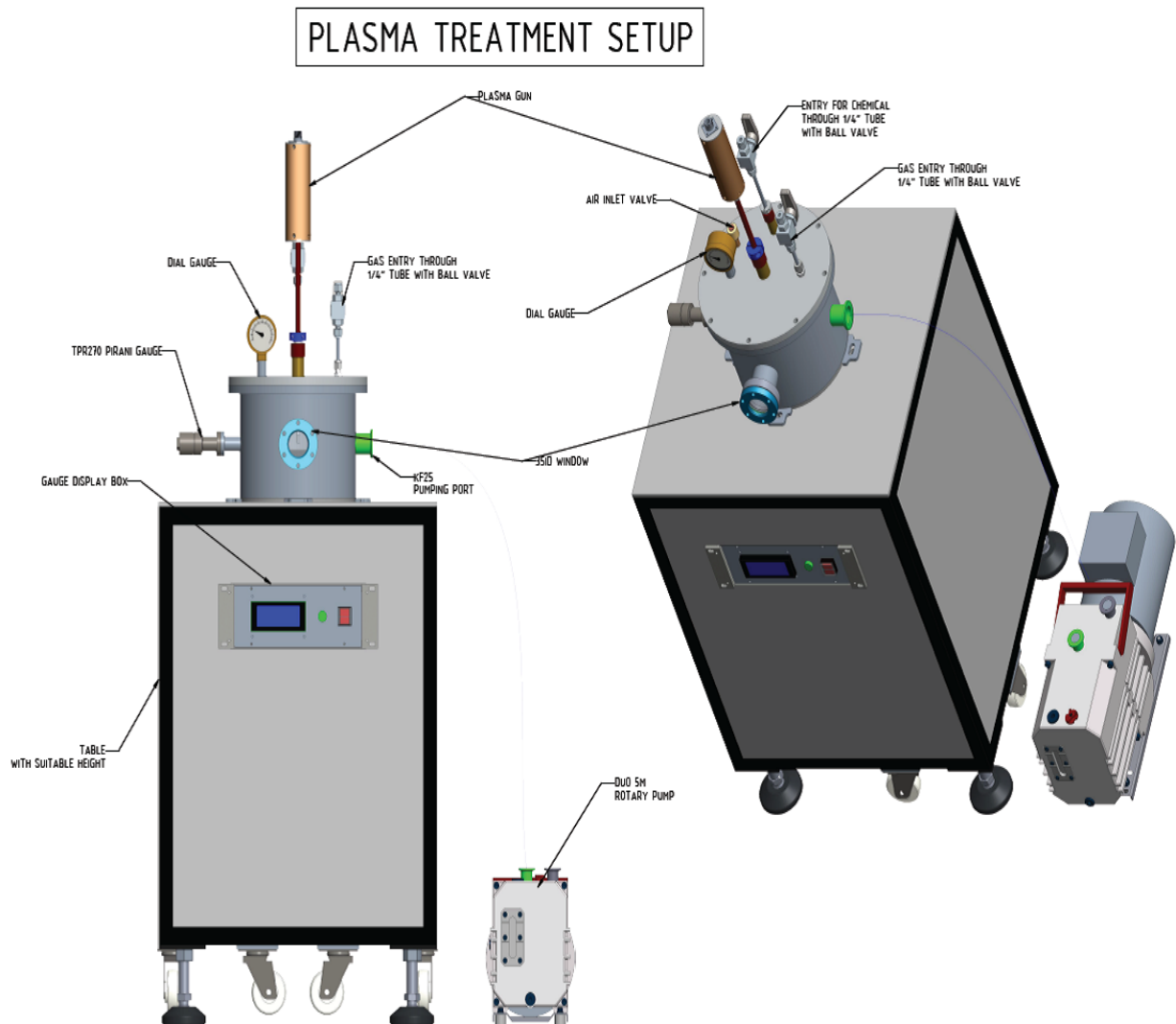

The main chamber:

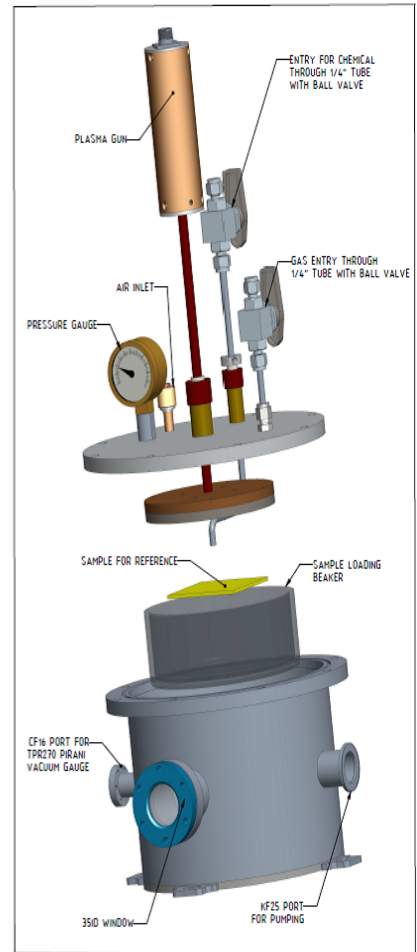
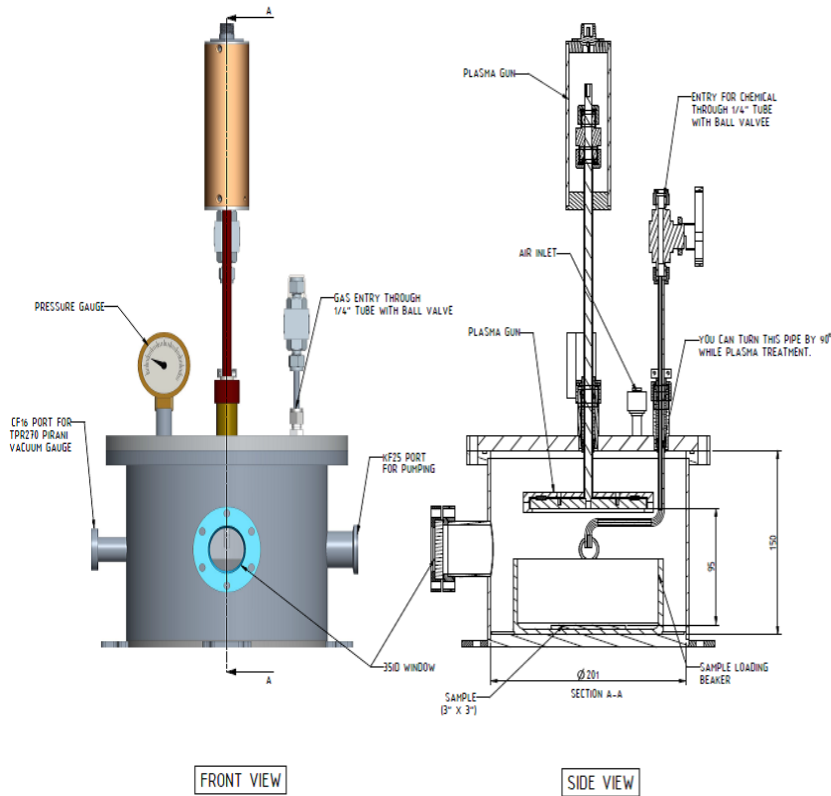

Please mention the brand, model no. & name of the equipment:

Place:

Date:

Signature and seal of the Manufacturer/Bidder

MANUFACTURERS' AUTHORIZATION FORM (MAF)
(ON THE LETTER HEAD OF THE COMPANY)

[NOTE: The Bidder shall require the Manufacturer to fill in this Form in accordance with the instructions indicated. This letter of authorization should be **on the letterhead of the Manufacturer** and should be signed by a person with the proper authority to sign documents that are binding on the Manufacturer. It should be included by the Bidder in its bid]

No. Dated

Date: **[insert date (as day, month and year) of Bid Submission]**

Tender No.: **[insert number from Invitation for Bids]**

To, Director
Rajiv Gandhi Institute of Petroleum Technology
Mubarakpur, Mukhtia, Bahadurpur
POST: Harbanshganj, Jais, Amethi - 229304

WHEREAS

We **[insert complete name of Manufacturer]**, who are official manufacturers of **[insert type of goods manufactured]**, having factories at **[insert full address of Manufacturers factories]**, do hereby authorize **[insert complete name of Bidder]** to submit a bid the purpose of which is to provide the following Goods, manufactured by us **[insert name and or brief description of the Goods]**, and to subsequently negotiate and sign the Contract.

We hereby extend our full guarantee and warranty in accordance with the General Conditions of Contract, with respect to the Goods offered by the above firm.

Signed: **[insert signature(s) of authorized representative(s) of the Manufacturer]**

Name: **[insert complete name(s) of authorized representative(s) of the Manufacturer]**

Title/Designation: **[insert title]**

Duly authorized to sign this Authorization on behalf of: **[insert complete name of Bidder]**

Dated on ____ day of _____, _____ **[insert date of signing]**

Yours faithfully,

(Name of manufacturers)

OR

SELF DECLARATION OF MANUFACTURING UNIT

PRICE REASONABILITY CERTIFICATE
(ON THE LETTER HEAD OF THE COMPANY)

It is certified that the rates quoted against Tender No.
datedfor the items vide our bid No.
datedare exclusively for supply to ACADEMIC and RESEARCH Institutions
and are not more than as charged to other Govt./PSU"s for similar supplies made in recent
past. If they have been approved by the Director, RGIPT and if at any stage it has been
found that the quoted rates are higher than the rates applicable to supply to Government
then in such condition RGIPT, Amethi, will have the right to cancel the approved rates and
to take legal action against the tenderer.

Yours faithfully,

(Name of manufacturers)

(Signature with date)

(Name and designation)

Duly authorized to sign tender for and on behalf of

DECLARATION (ACCEPTANCE OF TERMS & CONDITIONS)
(ON THE LETTER HEAD OF THE COMPANY)

1. I, Son/Daughter of Shri
Proprietor/ Partner/CEO/MD/Director/Authorized Signatory of M/s
..... am competent to sign this tender document.
2. I have carefully read and understood all the terms and conditions of the tender and hereby convey my acceptance of the same.
3. The information/ documents furnished along with the above application are true and authentic to the best of my knowledge and belief.
4. I/ we/ am are well aware of the fact that furnishing of any false information/ fabricated document would lead to rejection of my tender at any stage besides liabilities towards prosecution under appropriate law.
5. Each page of the tender document and papers submitted by my Company is authenticated, sealed and signed, and I take full responsibility for the entire documents submitted.

Date: -----

Place: -----

Signature of the Authorized Person

Full Name: -----

Company Seal: -----

DECLARATION SHEET

We, _____ hereby certify that all the information and data furnished by our organization with regard to this tender specification are true and complete to the best of our knowledge. I have gone through the specification, conditions and stipulations in details and agree to comply with the requirements and intent of specification.

This is certified that our organization has been authorized (Copy attached) by the OEM to participate in Tender. We further certified that our organization meets all the conditions of eligibility criteria laid down in this tender document. Moreover, OEM has agreed to support on regular basis with technology / product updates and extend support for the warranty.

The prices quoted in the financial bids are subsidized due to academic discount given to RGIPT, Jais, Amethi.

We, further specifically certify that our organization has not been Black-Listed/ De Listed or put to any Holiday by any Institutional Agency/ Govt. Department/ Public Sector Undertaking in the last three years.	
1. Phone	
2. Fax	
3. E-mail	
4. Contact Person Name	
5. Mobile Number	
6. TIN Number	
7. PAN Number	
8. (In case of on-line payment of Tender Fees) UTR No. (For Tender Fee)	
9. (In case of on-line payment of EMD) UTR No. (For EMD)	
10. Kindly provide bank details of the bidder in the following format: a) Name of the Bank	
b) Account Number	
c) Kindly attach scanned copy of one Cheque book page to enable us to return the EMD to unsuccessful bidder	

(Signature of the Tenderer)

Name:
Seal of the Company

NON-BLACKLISTING DECLARATION

It has been certified that all information provided in tender form is true and correct to the best of my knowledge and belief. No forged / tampered document(s) are produced with tender form for gaining unlawful advantage. We understand that RGIPT, Amethi is authorized to make enquiry to establish the facts claimed and obtain confidential reports from clients.

In case it is established that any information provided by us is false / misleading or in the circumstances where it is found that we have made any wrong claims, we are liable for forfeiture of EMD and or any penal action and other damages including withdrawal of all work/purchase orders being executed by us. **Further RGIPT, Amethi is also authorized to blacklist our firm/company/agency and debar us in participating in any tender/bid in future.**

I / We assure the Institute that neither I / We nor any of my / our workers will do any act/s which is improper / illegal during the execution in case the tender is awarded to us.

Neither I/We nor anybody on my/our behalf will indulge in any corrupt activities/practices in my/our dealing with the Institute.

Our Firm/Company/Agency is not been blacklisted or banned by any Central Government Department/ State Government Department, PSU, University, Autonomous Institute or Any other Govt. Organization.

Date

Signature of the Tenderer

Place

Stamp

Note: This certificate should be executed on duly notarized `100/- Non Judicial Stamp Paper.

List of Govt. Organization/Department/Institutes

List of Government Organization/Department/Institutes for whom the Bidder has undertaken such work during last three years (must be supported with work orders)		
Name of the Organization	Name of Contact Person	Contact No.

(Signature of the Tenderer)

Name:

Seal of the Company



RAJIV GANDHI INSTITUTE OF PETROLEUM TECHNOLOGY

CHECKLIST FOR SUBMISSION OF DOCUMENTS FOR FINANCIAL BID

For Exemptions:-

1. For Customs duty exemption in terms of Govt. Notification No. 51/96- Customs dated 23.07.1996 & 28/03 Customs dated 01.03.2003 and Central Excise duty Exemption in terms of govt. Notification No. 10/97 - Central Excise dated 01.03.1997 & 28/13- Central Excise dated 01.10.2013.
Institute DSIR Notification No. TU/V/RG-CDE(1083)/2021 Dated:09.09.2021
Valid up to 31.08.2026
2. For GST Exemption Notification No. 47/2017- Integrated tax (Rate).

The Company can bid in Foreign Currency or Indian Currency in the given format

The bidder may add rows as per requirement to include the prices of all components/ parts, warranties, installation etc. whichever applicable.

FINANCIAL BID – Plasma Treatment Set up

A. Financial Bid in Indian Currency:

I. Name of the Bidder/Tenderer:

Name & Model No of offered goods:

Tender No.:

Sl. No.	Details	Total Amount (In INR)
1	Basic Cost of Plasma Treatment Set up with accessories defined in Technical Specifications Statement of the Tender	
2	Add: Cost of Warranty	
3	Add: Packing & Forwarding Charges, If any	
4	Add: Installation & Commissioning Charges, if any	
5	Add: Transportation Charges up to RGIPT, Jais, Amethi, if any	
6	Add: GST (Taxes)	
Total Price (Sum of Sl. No 1 to 6) F.O.R RGIPT, Jais, Amethi Price		

Note: The Institute will provide DSIR & GST Exemption Certificate.

II. For Local Supplies -

Sl. No.	Details	Total Amount (In INR)
1	Cost of Local Supplies defined in Technical Specifications Statement of the Tender Document (Please mention the items)	
2	Add: Packing & Forwarding Charges, If any	
3	Add: Installation & Commissioning Charges, if any	
4	Add: Transportation Charges up to RGIPT, Jais, Amethi, if any	
5	Add: Cost of Warranty	
6	Add: GST (Taxes)	
Total Price (Sum of Sl. No 1 to 6) F.O.R RGIPT, Jais, Amethi Price		

- I. Total Bid price in Indian Currency (Equipment Cost with accessories):.....In words:.....
- II. Total Bid price in Indian currency (Local Supplies):.....
- III. In words.....

Grand Total (I+II) =

In words:

- a) Indian Agents Name & Address
- b) The cost of optional items shall be indicated separately
- c) In case the price quoted in Foreign Currency (Other than INR), for the purpose of comparison the Exchange Rate prevailing on the date of opening of Financial Bid will be considered.

Date

Signature of the Tenderer

Place

Stamp

B. Financial Bid in Foreign Currency:

**Price Schedule Form: Price schedule for goods being offered from abroad
In currency other than INR (Indian Rupees)
(Separate form to be used for each item offered)
(ON THE LETTER HEAD OF THE COMPANY)**

I. Name of the Bidder/Tenderer:

Name & Model No of offered goods:

Tender No.:

(Separate Prices should be defined for each instrument)

Sl. No.	Details (Basic Cost of Equipment with accessories)	Price per unit in (-)
A.	Country of origin	
	Payment in Foreign Currency	
1	C.I.F Price up to Indian Airport/port in foreign currency	
2	Total Price at Indian Airport /port (C.I.F)	
B.	Reimbursement of Expenses (in Indian Rupees only)	
3	**Custom Duty against DSIR certificate (Please mentioned % also)	
4	Custom clearance and other charges, if any (with breakup)	
5	Inland Charges for Insurance & transportation to RGIPT Jais, Amethi	
6	Installation, commissioning and training Charges, if any	
7	Cost of Warranty	
Total Price F.O.R RGIPT, Jais, Amethi Price (A + B) (Sum of Sl. No 1 to 7)		

**** RGIPT, Jais, Amethi have Custom/Excise Exemption Certificate.**

For Local Supplies -

Sl. No.	Details	Total Amount (In INR)
1	Cost of Local Supplies defined in Technical Specifications Statement of the Tender Document (Please mention the items) In INR only.	
2	Add: Packing & Forwarding Charges, If any	
3	Add: Installation & Commissioning Charges, if any	
4	Add: Transportation Charges up to RGIPT, Jais, Amethi, if any	
5	Add: Cost of Warranty	
6	Add: GST (Taxes)	
Total Price (Sum of Sl. No 1 to 6) F.O.R RGIPT, Jais, Amethi Price		

I. Total Bid price in **Foreign Currency** (Equipment Cost with accessories):.....
In words:.....

II. Total Bid price in Indian currency (Local Supplies):.....
In Words:.....

- a) Indian Agents Name & Address
- b) The cost of optional items shall be indicated separately
- c) In case the price quoted in Foreign Currency (Other than INR), for the purpose of comparison the Exchange Rate prevailing on the date of opening of Financial Bid will be considered.

Date

Signature of the Tenderer

Place

Stamp